

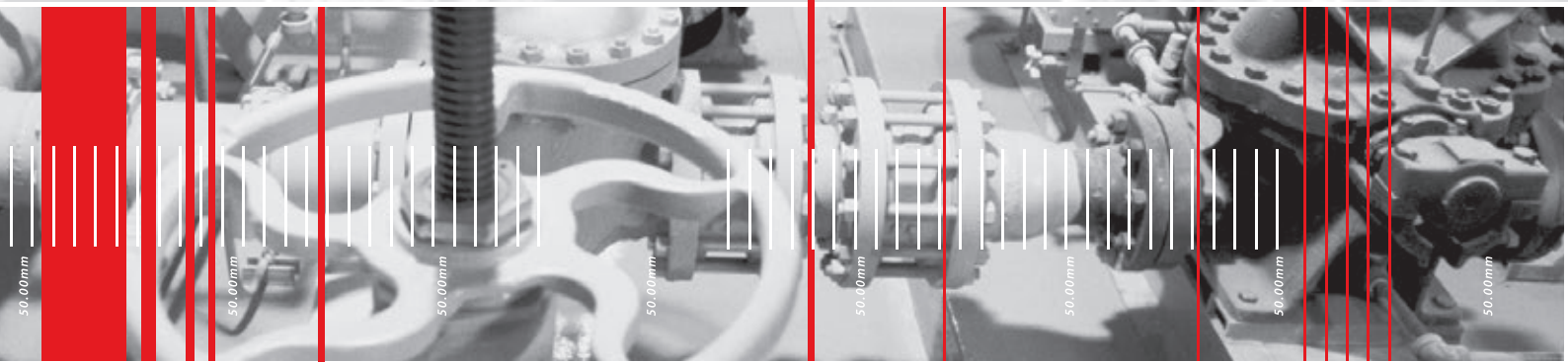

Total Valve Care.



Product Catalogue

ON-LINE VALVE LUBRICATION AND SEALING SERVICE

Version 11 / 2025



PRESSURELUBE
INTERNATIONAL

www.pressurelube.com.au



PRESSURELUBE
INTERNATIONAL

Pressure Lube International Pty Ltd

23 Jackson Street Bassendean

Western Australia 6054

Telephone +61 8 9379 1200

Facsimile +61 8 9279 9929

Email info@pressurelube.com.au

ABN 17 080 519 517



www.pressurelube.com.au

CONTENTS

Table of Contents

SECTION	PART NUMBER	PAGE
Maintenance Products		4
Liquid Valve Flush	PLI-200-HP-VF	4
Grease Form Valve Cleaner	PLI-200-HP-GFVC40	5
Valve Lubricant	PLI-200-HP-LUBE	6
Valve Sealant	PLI-200-HP-SEAL	7
Super Condensate Sealant (Grey)	PLI-200-HP-SC-SEAL	8
Anti Seize 2200	PLI-200-AS-2200	9
Stick Packing 686	PLI-200-SP-686	10
Stick Packing 636G	PLI-200-SP-636G	11
Fittings		13
Easiflow Vented Cap	PLI-EFLF-VC	15
Easiflow Long Stem	PLI-EFLF-LS	18
Easy Flow 60 Degrees	PLI-EFLF-60D	19
Easiflow Vented Cap Giant Button Head	PLI-EFLF-GBH	20
Cavity Plug	PLI-CP	21
Packing Glands	PLI-PG	22
Body Bleed	PLI-BB	23
Internal Check	PLI-ICF	24
Packing Injection Fitting	PLI-PIF	25
Adaptors		27
Lube Adaptor	PLI-LA	28
Safety Tools		29
Pressure Relief Tool	PLI-PRT	30
Leak Lock Fitting	PLI-LLF	31
Diesel Air Compressor Pumps & Equipment		33
Flush Pump - S.S.Tank Trolley	PLI-FP-SS-TT	34
Bucket Pump - Lightweight	PLI-BP-LW	35
PM3 Pump - 7,500 psi	PLI-PM3-7PSI	36
PM3 Pump - 14,000 psi	PLI-PM3-14PSI	37
Aluminium Trolley	PLI-AL-T	38
Open Skid Unit	PLI-OSU	39
Open Skid Unit	PLI-OSU-1	41
Open Skid Unit	PLI-SKID-6	42
Open Skid Unit	PLI-OSU-7	43
Diesel Air Compressor (Zone 2)	PLI-DPAC-Z2	44
Diesel Air Compressor	PLI-DPAC-ES	45
Calibrated Chart Recorder	PLI-CCR	47
Whip Hose	PLI-WP	48
Lubrication/Sealing Pump Operating Procedures		49



PRESSURELUBE
INTERNATIONAL

Liquid Valve Flush

PART NO: PLI-200-HP-VF

Our PL LIQUID VALVE FLUSH is developed to remove even the most stubborn of hydrocarbon deposits and old hydrocarbon sealants from the seal and spring areas of a valve, without damaging elastomers or seals. It will also dissolve waxes produced in oil production, thus allowing the valves to be effectively flushed prior to lubrication and sealing. It is applied with an air operated liquid injection pump.

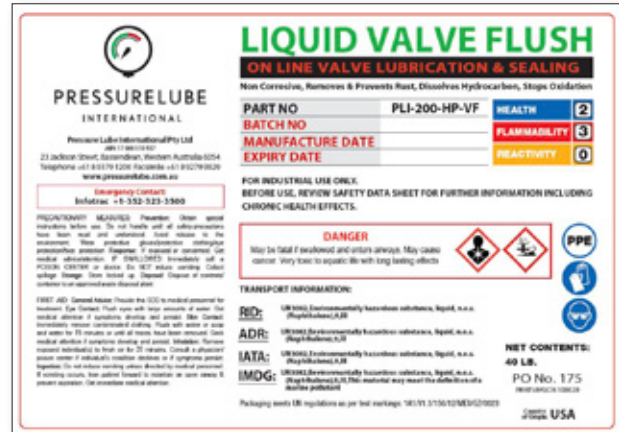

All products are being upgraded to reflect use of new synthetic oil immiscible in condensate and white gasoline, improved lubricity and elastomeric bridging properties.

PLI LIQUID VALVE FLUSH is a unique combination of valve penetrant and moisture displacer engineered for today's growing valve maintenance market.

PLI LIQUID VALVE FLUSH is a superior corrosion inhibitor because it safely removes old hydrocarbon deposits and also removes oxidation deposits.

PLI LIQUID VALVE FLUSH will also remove even the toughest sealant deposits that may have solidified in the seal pockets.

In addition to these benefits, it provides an excellent corrosion inhibiting film. This film contains no dangerous chlorinated solvents and provides unsurpassed protection in harsh conditions.

Recommended users of PLI LIQUID VALVE FLUSH include valve manufacturers, valve refurbishes, pipeline operators, geothermal power generation plants and geothermal well operators.

BENEFITS

- Corrosion, scale inhibitor and oxidation preventative
- Noncorrosive
- Harmless to valve elastomers
- Dissolves hydrocarbon deposits
- Loosens rust and scale
- Will clean up most metal surfaces
- Max temp range of 500°F

APPLICATION

PLI LIQUID VALVE FLUSH can be applied using an air operated liquid injection pump, or a hand held liquid injection pump.

RECOMMENDED USES

Flushing of seized valves prior to lubrication / sealing, so as to clear out the lubrication passageways, cleaning down of valves.

PACKAGING

20 litres

SAFETY DATA SHEET

Available for download from PLI website www.pressurelube.com.au

Manufactured in the USA by Lubchem for PLI formulation.



Grease Form Valve Cleaner

PART NO: PLI-200-HP-GFVC40

This product is a combination valve cleaner and penetrating lubricant engineered to free up and clean out difficult or impossible to operate lubricated valves.

Pressure Lube Valve Cleaner penetrates and cleans residual gum, lacquer, hardened sealants and lubricants. Valve Cleaner also penetrates and loosens rust and corrosion deposits extending the life and performance of all types of lubricated valves. When used regularly it will prevent additional build up.

FEATURES

- Compatible with all valve lubricants
- Cuts residual gum and lacquer deposits
- Removes rust and corrosion
- Do not use in oxygen service
- Temperature Range -40 to 400°F
- Ideal for valves orientated at an angle

APPLICATION PROCEDURE

Apply the Valve Cleaner with a PLI bucket pump. Turn valve slowly and repeat the process until valve opens freely. After the valve is operable, lubricate with one of PLI's high quality valve lubricants, or sealant.

SAFETY DATA SHEET

Available for download from PLI website
www.pressurelube.com.au

Manufactured in the USA by Lubchem for PLI formulation.

 PRESSURELUBE INTERNATIONAL		Pressure Lube International Pty Ltd ABN 17 006 116 117 Jackson Street, Bassendean Western Australia 6054 Telephone +61 8 9379 1200 Facsimile +61 8 9279 9929 www.pressurelube.com.au
ON LINE VALVE LUBRICATION & SEALING		
PRODUCT	GREASE FORM VALVE CLEANER	
PART NO	PLI-200-HP-GFVC40	
BATCH NO		
MANUFACTURE DATE		
EXPIRY DATE		
GREASE FORM VALVE CLEANER ???? ???? ???? ???? APPLICATION ????	NOTE: NON HAZARDOUS GOODS PRODUCT CAN BE SHIPPED BY AIR AUSTRALIA CONTACT Tel: +61-8-9379 1200 Fax: +61-8-9279 9929 PLI????	





PRESSURELUBE
INTERNATIONAL

Valve Lubricant

PART NO: PLI-200-HP-LUBE

We developed our **SYNTHETIC VALVE LUBRICANT** to be used in continual P.M. systems as a cheaper alternative to costly sealants. PLI's synthetic lubricant is resilient to all products coming up a production string or produced in a gas processing plant. This reduces the need to stock various types of lubricants and therefore reduces costs. Since it is fully synthetic it will also not harden or block up the injection ports reducing torque and giving a perfect seal even after repeated cycling. This lubricant can be used in ball, gate and plug valves. For geothermal valves, you may use the specially formulated **SYNTHETIC GEOTHERMAL LUBRICANT**, a high temperature (up to 900F) lubricant, developed for geothermal use.

 PRESSURELUBE INTERNATIONAL		PressureLube International Pty Ltd ABN 17 080 519 517 Jackson Street, Bassendean Western Australia 6054 Telephone +61 8 9379 1200 Facsimile +61 8 9279 9929 www.pressurelube.com.au
ON LINE VALVE LUBRICATION & SEALING		
PRODUCT	VALVE LUBRICANT	
PART NO	PLI- 200-HP-LUBE	
BATCH NO		
MANUFACTURE DATE		
EXPIRY DATE		
SYNTHETIC VALVE LUBRICANT 100% SYNTHETIC NO FILLERS Protects against corrosion Resists H ₂ S, CO ₂ , Water, Acid – Brine Will not harden in valve		NOTE: NON HAZARDOUS GOODS PRODUCT CAN BE SHIPPED BY AIR
APPLICATION Valve Sealant for Oil & Gas Industry		AUSTRALIA CONTACT Tel: +61-8-9379 1200 Fax: +61-8-9279 9929 PLI3154

PLI HIGH PERFORMANCE SYNTHETIC VALVE LUBRICANT is an excellent valve lubricant which reduces friction during operation of valves. PLI HIGH PERFORMANCE SYNTHETIC VALVE LUBRICANT allows valves to turn easily, thereby extending their lifetime and performance.

PLI HIGH PERFORMANCE SYNTHETIC VALVE LUBRICANT is resistant to solvents and chemicals including hydrogen sulphide, crude oil, diesel, carbon dioxide, hydrochloric acid, brine, water and condensates, as well as drilling muds. PLI HIGH PERFORMANCE SYNTHETIC VALVE LUBRICANT is waterproof, will not harden, and adheres to metal assuring protection against rust and corrosion.



BENEFITS

- Non-melting and non-hardening
- Rust, corrosion and oxidation preventative
- Resists hydrogen sulphide, crude oil, oilfield brine water, diesel and sea water
- Insoluble in water
- Services temperatures up to 600°F
- Will not wash out

APPLICATION

PLI HIGH PERFORMANCE SYNTHETIC VALVE LUBRICANT can be applied using an air operated lubrication pump, or a hand held great gun or a volume bucket pump.

RECOMMENDED USERS

by valve manufacturers, valve refurbishes, pipeline and wellhead companies, refineries, chemical processing plants and LNG plants.

PACKAGING

40Lb Pails (20 Ltr)

SAFETY DATA SHEET

Available for download from PLI website
www.pressurelube.com.au

Manufactured in the USA by Lubchem for PLI formulation.

Valve Sealant

PART NO: PLI-200-HP-SEAL

PLI's **SYNTHETIC VALVE SEALANT** is a last line of defence in valve maintenance, i.e. a valve must be sealed at all costs to eliminate the need for an untimely shut down. Our valve sealant contains no PTFE-fillers, will not harden and is excellent for emergency seat renewal and low pressure sealing problems. It comes in various grades, but the standard grade is good for H₂S and CO₂ services. The 2010 product will be immiscible in condensate.

 PRESSURELUBE INTERNATIONAL		Pressure Lube International Pty Ltd A/NZ 17 088515117 Jackson Street, Bassendean Western Australia 6054 Telephone +61 8 9279 1200 Facsimile +61 8 9279 9929 www.pressurelube.com.au
ON LINE VALVE LUBRICATION & SEALING		
PRODUCT	VALVE SEALANT	
PART NO	PLI- 200-HP-SEAL	
BATCH NO		
MANUFACTURE DATE		
EXPIRY DATE		
SYNTHETIC VALVE LUBRICANT 100% SYNTHETIC NO FILLERS Protects against corrosion Resists H ₂ S, CO ₂ , Water, Acid - Brine Will not harden in valve	NOTE: NON HAZARDOUS GOODS PRODUCT CAN BE SHIPPED BY AIR	
APPLICATION Valve Sealant for Oil & Gas Industry	AUSTRALIA CONTACT Tel: +61-8-9379 1200 Fax: +61-8-9279 9929 PLI3154	

By using a unique combination of 100% fully synthetic oils and a propriety thickener, PLI HIGH PERFORMANCE VALVE SEALANT was formulated to provide a superior lubricating and sealing compound that is unsurpassed in performance.

There are no fillers such as clay, bentonite or soaps or PTFE PLI HIGH PERFORMANCE VALVE SEALANT does not rely on these fillers as bridging agents.

When injected into the valve, PLI HIGH PERFORMANCE VALVE SEALANT lubricates and seals with as much as 90 percent greater efficiency. PLI HIGH PERFORMANCE VALVE SEALANT will not harden in valve seats or lubrication channels thus eliminating frequent flushing of the valve and allowing for torque operation.

PLI HIGH PERFORMANCE VALVE SEALANT will resist washouts by crude condensate, water, gas, diesel, hydrocarbon acid, oil field brine, H₂S, CO₂ and is insoluble in water. It can withstand a wide temperature range form -60F to 500F.

BENEFITS

- 100% Synthetic
- Does not contain fillers
- Low friction coefficient
- Resistant to water washout
- Protects from corrosion
- Effective temperature range of -60°F to 500°F
- Protects against H₂S and CO₂

APPLICATION

PLI HIGH PERFORMANCE VALVE SEALANT can be applied using an air operated lubrication pump, a hand held grease gun or a volume bucket pump.

RECOMMENDED USERS

By Valve manufacturers, valve refurbishes, pipeline and wellhead companies, refineries and LNG plants.

PACKAGING

40Lb Pails (20 Ltr)

SAFETY DATA SHEET

Available for download from PLI website
www.pressurelube.com.au

Manufactured in the USA by Lubchem for PLI formulation.





PRESSURELUBE
INTERNATIONAL

Super Condensate Sealant (Grey)

PART NO: PLI-200-HP-SC-SEAL

PLI SUPER CONDENSATE VALVE SEALANT (GREY) is a last line of defence in valve maintenance, i.e. a valve must be sealed at all costs to eliminate the need for an untimely shut down. Our valve sealant contains no PTFE-fillers, will not harden and is excellent for emergency seat renewal and low pressure sealing problems. It is designed for H²S and CO² service and is immiscible in condensate. This elevates the problem of valves becoming seized or stiff to cycle in condensate service, and improves valves integrity to seal online.

PACKAGING

40Lb Pails (20 Ltr)

PART NUMBER

PLI-200-HP-SC-SEAL

SAFETY DATA SHEET

Available for download from PLI website
www.pressurelube.com.au

Manufactured in the USA by
Lubchem for PLI formulation.

 PRESSURELUBE INTERNATIONAL		Pressure Lube International Pty Ltd ABN 7 000 579 517 Jackson Street, Bassendean Western Australia 6054 Telephone +61 8 9379 1200 Facsimile +61 8 9279 9929 www.pressurelube.com.au
ON LINE VALVE LUBRICATION & SEALING		
PRODUCT	SUPER CONDENSATE SEALANT (GREY)	
PART NO	PLI-200-HP-SC-SEAL	
BATCH NO		
MANUFACTURE DATE		
EXPIRY DATE		
SUPER BLUE VALVE SEALANT 100% Synthetic No Fillers Protects against corrosion Resists - Condensate H2S, CO2 Water, Acid, Brine Will not harden in valve APPLICATION Valve Sealant for Oil & Gas Industry	NOTE: NON HAZARDOUS GOODS PRODUCT CAN BE SHIPPED BY AIR AUSTRALIA CONTACT Tel: +61-8-9379 1200 Fax: +61-8-9279 9929 MADE IN USA PLI 0000	



Anti Seize 2200

PART NO: PLI-200-AS-2200

The PLI ANTI SEIZE 2200 is a synthetic oil based graphite aluminium powder. An anti-seize paste for bushing, bearings, gears and chains. The application resists chemicals, gases (except oxygen) and solvents where two metals meet.

PACKAGING

1Lb Can (454g)

PART NUMBER

PLI-200-AS-2200

SAFETY DATA SHEET

Available for download from PLI website
www.pressurelube.com.au

 PRESSURELUBE INTERNATIONAL		Pressure Lube International Pty Ltd AUL 17 088 516 517 Jackson Street, Bassendean Western Australia 6054 Telephone +61 8 9379 1200 Facsimile +61 8 9279 9929 www.pressurelube.com.au
ON LINE VALVE LUBRICATION & SEALING		
PRODUCT	ANTI SEIZE 2200	
PART NO	PLI-200-AS-2200	
BATCH NO		
MANUFACTURE DATE		
EXPIRY DATE		
<small>SYNTHETIC OIL BASE GRAPHITE ALUMINIUM POWDER ANTI-SEIZE PASTE FOR: Bushing, Bearings, Gears, Chains, etc -65°F to 2200°F APPLICATION Resists chemicals, gases (except oxygen) and solvents where 2 metal surfaces meet</small>		<small>NOTE: NON HAZARDOUS GOODS PRODUCT CAN BE SHIPPED BY AIR</small> <small>AUSTRALIA CONTACT Tel: +61-8-9379 1200 Fax: +61-8-9279 9929 MADE IN USA PLI 0000</small>





PRESSURELUBE
INTERNATIONAL

Stick Packing 686

PART NO: PLI-200-SP-686

STICK PACKING 686 is a clean odourless, pliable packing used to seal stuffing boxes. 686 is a petroleum hydrocarbon free stick packing made with LIQUILON®*. 686 continues to seal and lubricate long after conventional packing has failed. Regardless of the size of the stuffing box, 686 will form itself to the configuration of the box and shaft and compensates for wear by remoulding itself. 686 can be used as a supplement to worn conventional packing or intervals with conventional packing. 686 services temperatures to 400°F (204°C) and pressures up to 10,000 psi. 686 Packing is unaffected by most acids, oils, caustics, and common solvents.

TYPICAL OBSERVATIONS

- Colour:** Green
- Odour:** None
- Form:** Self Forming Sticks
- Shape:** Square
- Size:** 1/2" x 1/2" x 2 1/2"
- Equilateral**
- Active Component:** LIQUILON®*
- Specific Gravity:** 1.4
- Water-Repellent:** Yes
- Water-Resistant:** Yes
- Service Temperature:** 400°F (204°C)
- Solubility in Water:** Insoluble

PACKAGING

1Lb Jar (454g)

PART NUMBER

PLI-200-SP-686

SAFETY DATA SHEET

Available for download from PLI website
www.pressurelube.com.au

 PRESSURELUBE INTERNATIONAL		Pressure Lube International Pty Ltd ABN 17 005 51517 Jackson Street, Bassendean Western Australia 6054 Telephone +61 8 9379 1200 Facsimile +61 8 9279 9929 www.pressurelube.com.au
ON LINE VALVE LUBRICATION & SEALING		
PRODUCT	STICK PACKING 686	
PART NO	PLI-200-SP-686	
BATCH NO		
MANUFACTURE DATE		
EXPIRY DATE		
SYNTHETIC SELF-FORM PACKING Petroleum Hydrocarbon Free Low Friction Coefficient Shaft Sealer Service Temp to Above 204°C Apply Whole or Part Stick		NOTE: NON HAZARDOUS GOODS PRODUCT CAN BE SHIPPED BY AIR
APPLICATION Seals Worn Scratched Shaft Surfaces Unaffected by acids, oils, caustics, common solvents		AUSTRALIA CONTACT Tel: +61-8-9379 1200 Fax: +61-8-9279 9929 MADE IN USA

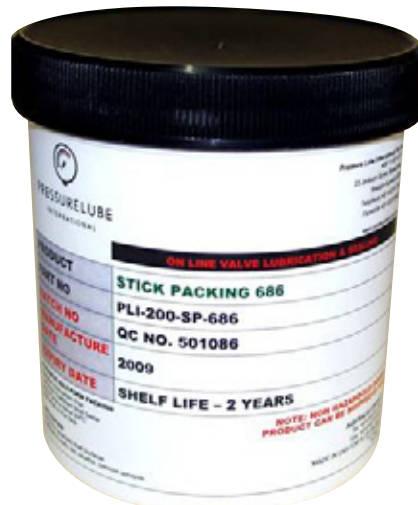

Stick Packing 636G

PART NO: PLI-200-SP-636G

STICK PACKING 636G is a clean, odourless, pliable packing used to seal stuffing boxes. Made with LIQUILON®*, 636G continues to seal and lubricate long after conventional packing has failed. Regardless of the size of the stuffing box, 636G forms itself to the configuration of the box and shaft and compensates for wear by remoulding itself. 636G can be used as a supplement to worn conventional packing or intervals with conventional packing. 636G serves temperatures to >400°F (>204°C) and pressures to 10,000 psi. 636G is unaffected by acids, oils, caustics, or common solvents.

TYPICAL OBSERVATIONS

Form Moldable sticks

Shape Triangular prisms

Size ½" x ½" x ½" x 2½"

Equilateral

Color Green

Odor None

Active Component LIQUILON®

Water-Repellant Yes

Water-Resistant Yes

Service Temperature Up to >400°F (>204°C)

Service Pressure Up to 10,000 psi

Solubility in Water Insoluble

Hardness (Durometer) 50 – 60

PACKAGING

1Lb Jar (454g)

PART NUMBER

PLI-200-SP-636G

SAFETY DATA SHEET

Available for download from PLI website
www.pressurelube.com.au

 PRESSURELUBE INTERNATIONAL		Pressure Lube International Pty Ltd ABN 17 080 516 517 Jackson Street, Bassendean Western Australia 6004 Telephone +61 8 9379 1200 Facsimile +61 8 9279 9929 www.pressurelube.com.au
ON LINE VALVE LUBRICATION & SEALING		
PRODUCT	STICK PACKING 636 G	
PART NO	PLI-200-SP-636G	
BATCH NO		
MANUFACTURE DATE		
EXPIRY DATE		
SYNTHETIC SELF-FORM PACKING Petroleum Hydrocarbon Free Low Friction Coefficient Shaft Sealer Service Temp to Above 204°C Apply Whole or Part Stick		NOTE: NON HAZARDOUS GOODS PRODUCT CAN BE SHIPPED BY AIR
APPLICATION Seals Worn/Scratched Shaft Surfaces Unaffected by acids, oils, caustics, common solvents		
		AUSTRALIA CONTACT Tel: +61 8-9379 1200 Fax: +61 8-9279 9929 MADE IN USA

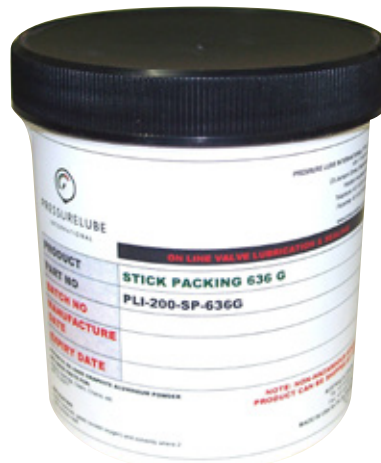



PRESSURELUBE
INTERNATIONAL



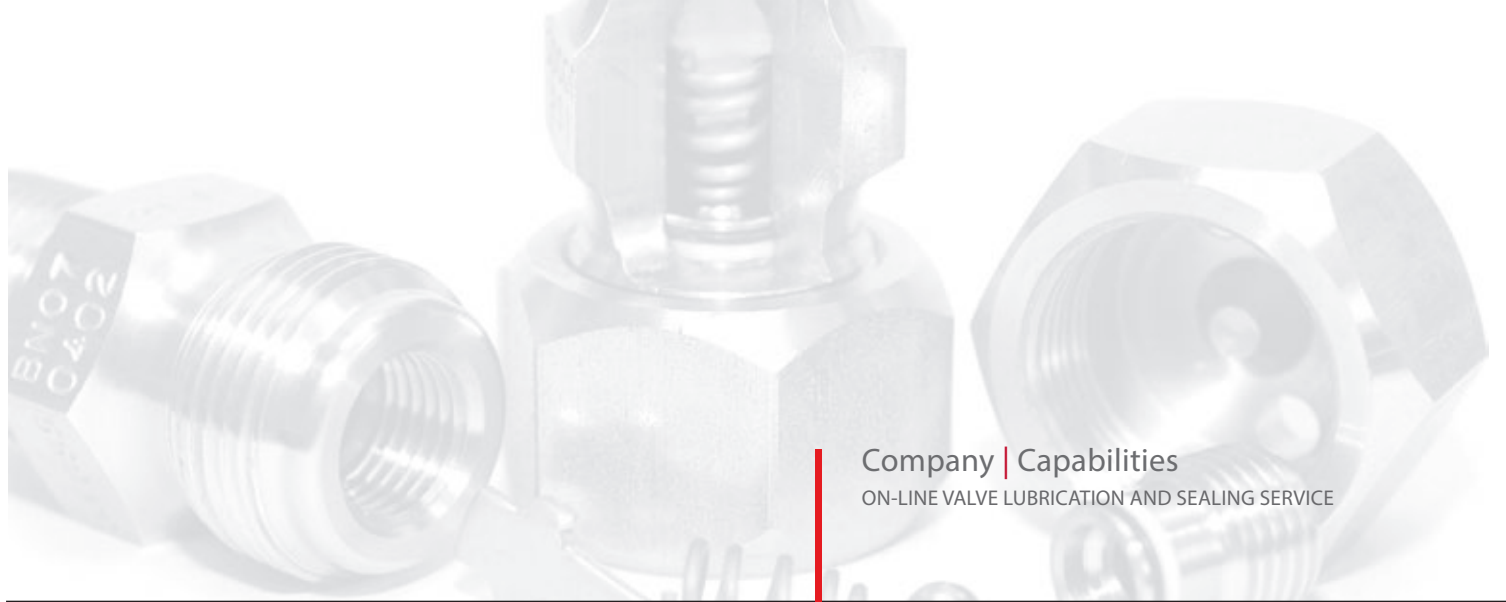

Company | Capabilities

ON-LINE VALVE LUBRICATION AND SEALING SERVICE

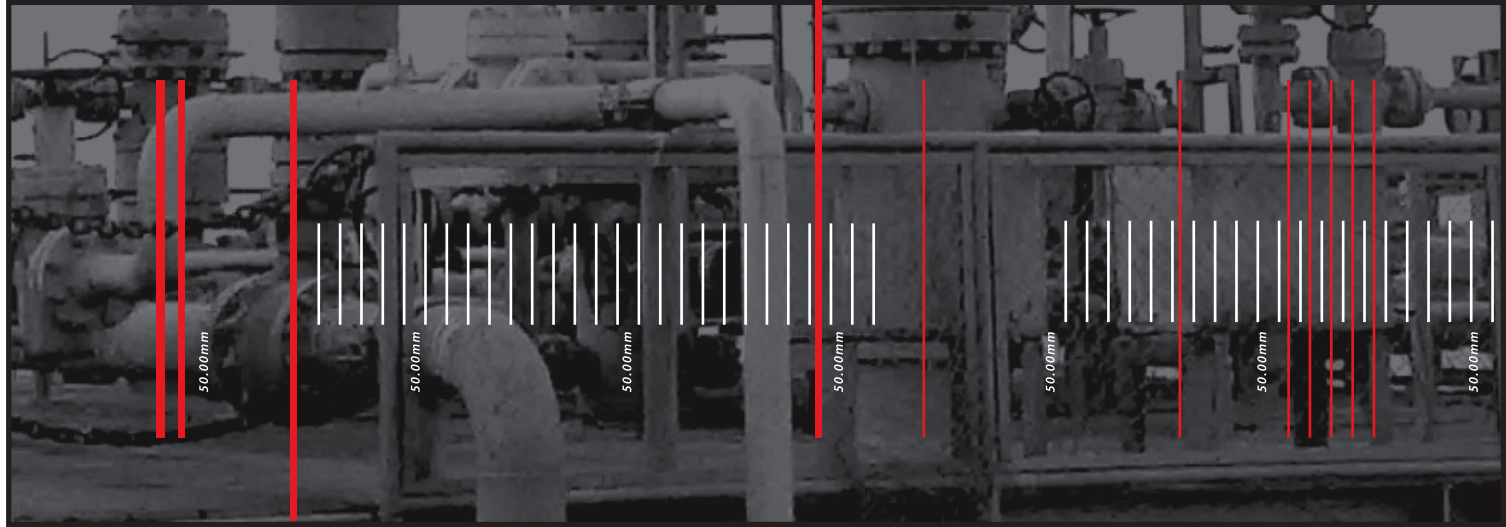

Fittings

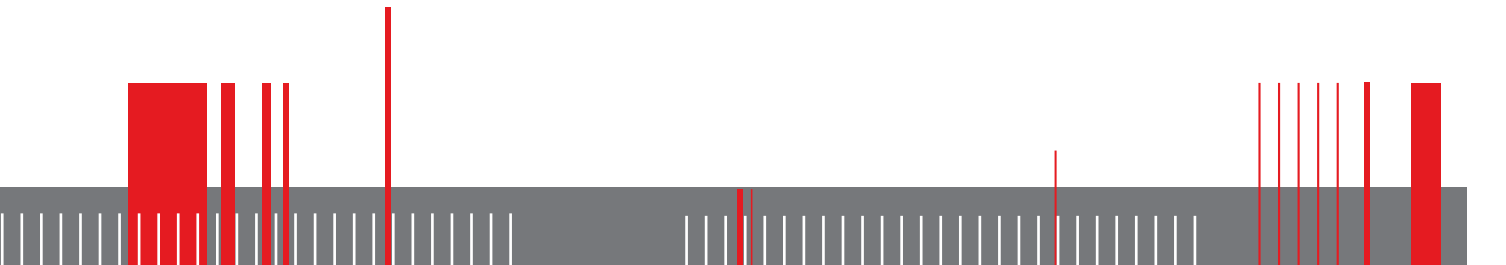



PRESSURELUBE
INTERNATIONAL

MANUFACTURER DATA REPORT (MDR) JUNE 2011
10,000 PSI STAINLESS STEEL LUBRICANT FITTINGS ¼" NPT to 1" NPT

Pressure Lube International Pty Ltd manufactures lubrication injection fittings under the following model numbers:

PLI-EFLF-VC	-	Easiflow Vented Cap
PLI-EFLF-LS	-	Easiflow Long Stem
PLI-EFLF-60D	-	Easiflow 60 Degrees
PLI-EFLF-GBH	-	Easiflow Vented Cap Giant Button Head

The design of all fittings conform to AS1210-2010 Pressure Vessels Standard.

Materials conform to the following standards:

1. AISI 316 to ASME SA 182, ASTM A276 and ASTM A 479 (bodies, caps & plugs)
2. Inconel springs to UNS no. 660, ASTM B163, ASME SB-163
3. Monel K500 balls UNS no. 5500, ASTM B865
4. NACE MR 0175 is applicable to all the above materials
5. NPT threads comply to ANSI BI.20.1

The fittings having been independently tested by Age Developments Pty Ltd to a burst test of 50,000psi (344.7MPa) without failure are rated to 10,000psi (68.9MPa). The design of the Easiflow Lubrication fitting has been assessed as being in accordance with the requirements of AS1210-2010 with a design pressure of 92.6MPa.

The design is verified independently by K.J. Beer Pty Ltd consulting engineers.

Signed as a true and correct record

John R. Worner BSc (Metallurgy)
Managing Director

Easiflow Vented Cap

PART NO: PLI-EFLF-VC

PREAMBLE

The philosophy behind the latest Lubrication Injection Fittings places great importance on the integrity of back seating (non return) capacity.

In cases where check valves within a valve body at lubricant injection points fail to back seat in service, the grease or lubricant fitting must seal under line pressures.

Furthermore, modern lubrication injection pumps are capable of generating 7,500 Psi. The new fitting is tested and rated to 10,000 PSI. Some other patented fittings in 1/4" size do not rate to even 7,500 because of wall thicknesses between threads being less than Engineering Minimums.

The spring is tapered to ensure easy flow of lubricant outside and through the fitting, avoiding solid locking. The top loaded spring and ball retained by the pressed tee piece prevents blow out.

MATERIAL SPECIFICATION

PLUG, BODY & CAP

316 Stainless Steel

SPRING

Tapered shape in Inconel 600

BALL

Monel K500

O'RING

Nitrile 70/90 D. Plus Teflon Backing Washer

TAPERED SPRING HOLDER

316 Stainless 2B finish

EASIFLOW ORIFICES

Inlet 5MM Dia, Outlet 6MM Dia

THREADS

Available 1/4", 3/8", 1/2" NPT. Standard. Other threads available on request.

PRESSURE RATING

10,000 PSI.

SEALING

Observe primary metal/metal seals of plug to body and ball to plug

Fire-safe

Secondary back-up seal by O-Ring

QUALITY ASSURANCE & MARKINGS

Basis of AS3902 (ISO 9002) full material certification. Marked with Grade, Pressure Rating, Quality Batch No. Quality batch number eg (BN 970203) will relate to Material Heat Certificates and Batch sample Stub Ends held at our factory in Australia, in this case batch number three produced in February 1997.

GAUGING & TESTING

All threads gauge tested. All fittings pressure tested, to 100 PSI bubble.

EASIFLOW CHARACTERISTICS

By increasing the outlet orifice size from the inlet orifice, lubricant and sealant flow is enhanced. By tapering the spring and holder, in the event of sealant hardening, i.e. if non PLI sealant were used, the wedge effect of the spring and retainer will assist with flushing and breakdown of a solidified mass. In the case of some fittings with parallel springs it is possible that the spring acts as an anchor reinforcement impeding complete dislodgment by flushing pressure.

VENTED CAP

The cone within the vented cap seals metal to metal on the inlet orifice taper.

ASSEMBLY

Ball location sealing point is polished on assembly by a controlled hammer peen. Plug is screwed into place and torqued with non-standard Hexagon Key and should not be removed. Each fitting is then pressure tested for thread and ball seal integrity.

SEALS

By incorporating primary seals of metal to metal design the fitting becomes "A Fire Safe Check Valve". This can be seen on the drawing plug to body and ball to plug,

If unforeseen field plug removal and replacement allows a hair or minute dirt particle onto the seat area plug to body, the secondary O-Ring Seal on the plug acts as a back-up only and seals the fitting when needed. Any disassembly must be noted, reported and the fitting tagged for replacement at the next maintenance or shut down. If necessary, the fitting may be returned to the factory for a new plug.

PART NUMBER

PLI-EFLF-VC



Easiflow Vented Cap

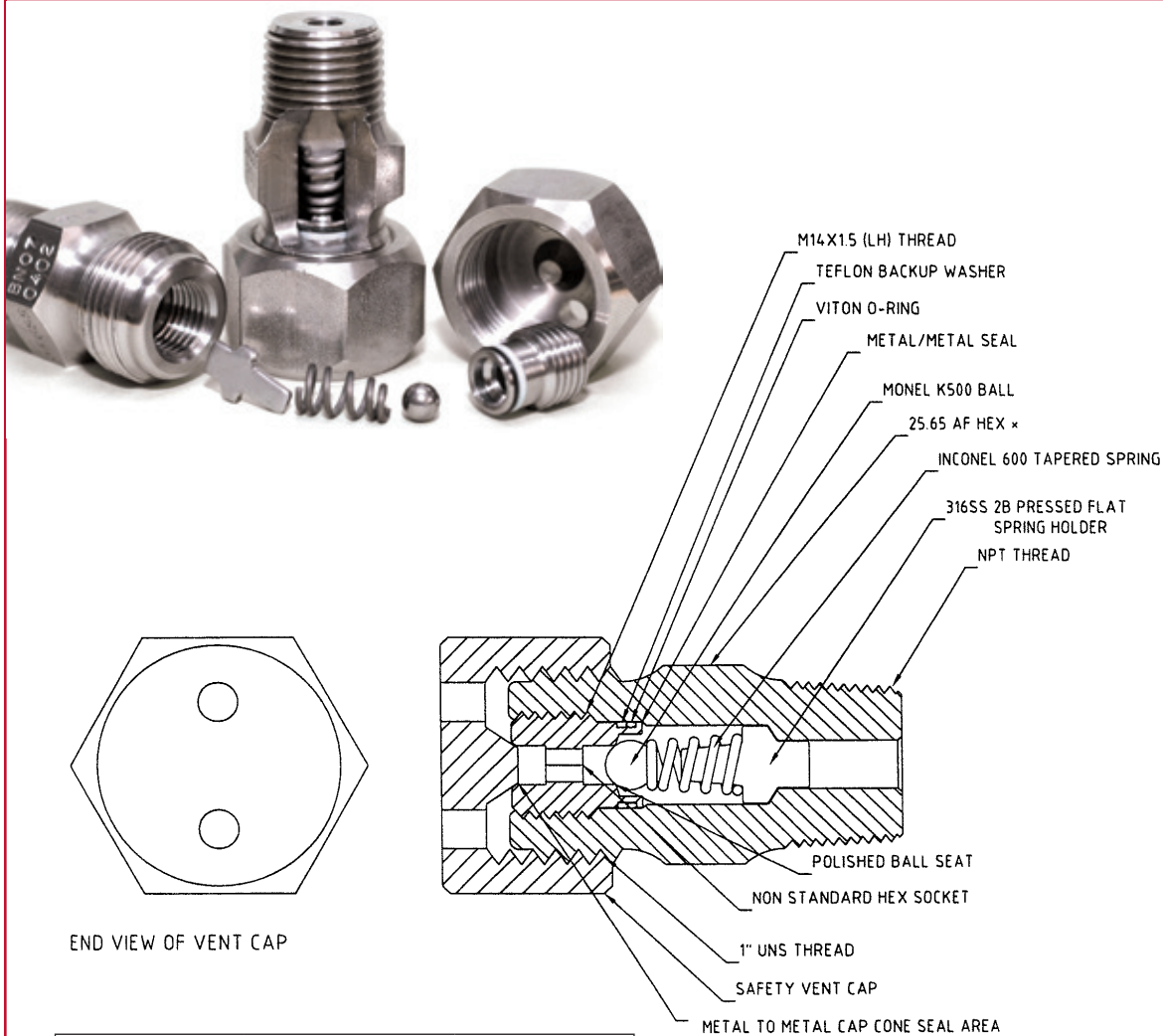

END VIEW OF VENT CAP

ASSEMBLY DRAWING

EASY FLOW LUBRICATION FITTING		
PART#	THREAD SIZE	HEX AF*
PLI-EFLF18	1/8" NPT	25.65
PLI-EFLF14	1/4" NPT	25.65
PLI-EFLF38	3/8" NPT	25.65
PLI-EFLF12	1/2" NPT	25.65
PLI-EFLF34	3/4" NPT	33.05
PLI-EFLF1	1" NPT	39.00

OPTIONS:

- Other threads available on request, including UNC Parallel Threads
- Ball material options include Tungsten Carbide (WC)
- Spring material options include INCONEL X-750
- O-Ring material options available

AS 1210

PROPRIETARY NOTICE:

THIS DATA AND THE INFORMATION CONTAINED HEREIN ARE THE PROPERTY OF PRESSURE LUBE INTERNATIONAL AND SHALL NOT BE USED OR REPRODUCED OR DISCLOSED FOR ANY PURPOSE WITHOUT THE EXPRESS CONSENT OF PRESSURE LUBE INTERNATIONAL.



AGE DEVELOPMENTS PTY. LTD.

8 PITINO COURT, OSBORNE PARK,
WESTERN AUSTRALIA 6017.
PHONE: 61-9-446 9644 ALL HOURS
FAX : 61-9-446 7090 ALL HOURS

A.C.N. 009 188 989



HYDROSTATIC PRESSURE TEST CERTIFICATE

TEST DETAILS

Date of Test: 1/12/94	Client: Press Form (W.A.) Pty Ltd	Report No: 1152
Test Type: Hydrostatic Pressure Proof & Burst Tests		
Test Item Details: 1 off EASIFLOW LUBRICANT INJECTION FITTING with 1/4" NPT Male connection.		
Specification: Proof Test Pressure - 10,000 psi		

TEST RESULTS

Test Item Markings	Temp (deg.C)	Time (min)	Test Pressure (psi)	Comments
PROOF TEST	Amb.	5	10,000	
BURST TEST	Amb.	N/A	50,000	NO FAILURE

Observations:

- 1) No leakage or distortion noted.
- 2) Test gauge accuracy for Proof Test = ±150 psi.
- 3) Test gauge accuracy for Burst Test = ±500 psi.
- 4) Burst test was terminated at limit of test equipment.

Markings: Engraved "AGE 1152" on hex flat.

Approved Signatory	Name Clem Rowe	Signature 	Date 2/12/94
--------------------	-------------------	---------------	-----------------



This certificate may not be reproduced except in full. This laboratory is registered with the National Association of Testing Authorities of Australia. The tests reported here have been performed in accordance with its terms of registration.

Reg No:2227



PRESSURELUBE
INTERNATIONAL

EasiFlow Long Stem

PART NO: PLI-EFLF-LS

PART NUMBER
PLI-EFLF-LS



NPT TAPPED THREAD

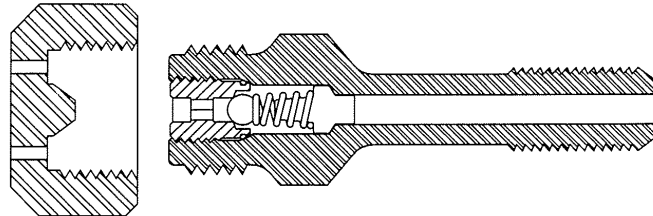

PARALLEL THREAD

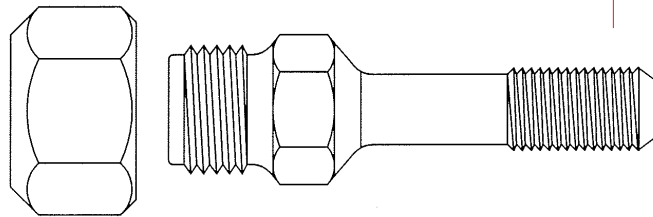

Long Stems Coupled With Parallel Threads are Available to Suit Any Requirement.

EasiFlow Lubrication Fitting Long Stem

- PLI-EFLF-LS14
- PLI-EFLF-LS38
- PLI-EFLF-LS12
- PLI-EFLF-LS78
- PLI-EFLF-GBH-LS14
- PLI-EFLF-GBH-LS38
- PLI-EFLF-GBH-LS12
- PLI-EFLF-GBH-LS78

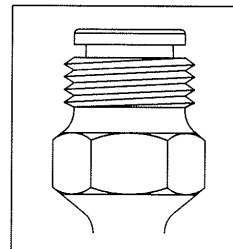

AS1210

Combination GBH Fitting Available

Suits Both 1" UNS and Giant Button Head Attachment

*n.b. (the giant head button reduces pressure rating of the fitting)

PROPRIETARY NOTICE:
THIS DATA AND THE INFORMATION CONTAINED HEREIN ARE THE PROPERTY OF PRESSURE LUBE INTERNATIONAL AND SHALL NOT BE USED OR REPRODUCED OR DISCLOSED FOR ANY PURPOSE WITHOUT THE EXPRESS CONSENT OF PRESSURE LUBE INTERNATIONAL.



ON LINE VALVE LUBRICATION & SEALING

23 JACKSON STREET, BASSENDEAN
WESTERN AUSTRALIA 6054
PHONE: +61-8-9379 1200 FAX: 61-8-9279 9929

TITLE: PLI EASY FLOW LUBE FITTING LONG STEM

DRAWING NUMBER: PLI-EFLF-LS

DRAWN BY: DAVID BRAMLEY

© COPYRIGHT

DATE: 3/5/05

Easy Flow 60 Degrees

PART NO: PLI-EFLF-60D

This image of the Easy Flow Lube Fitting shows the parallel thread and 60 degree sealing shoulder.

PART NUMBER

PLI-EFLF-60D

AS 1210

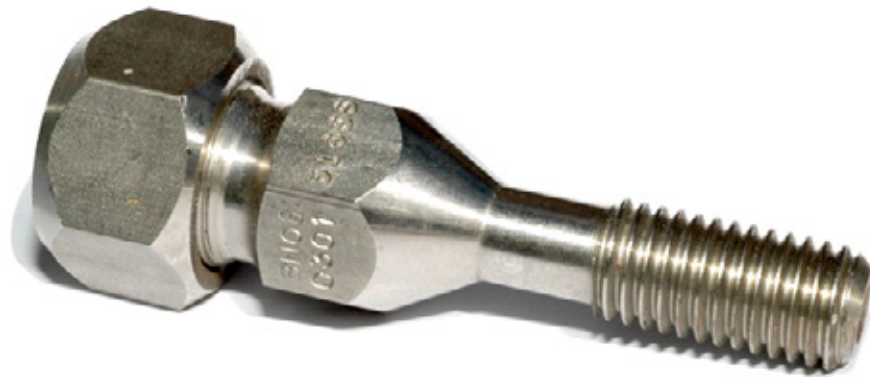

Long stem or short stem and thread type are available on request.



Easiflow Vented Cap Giant Button Head

PART NO: PLI-EFLF-GBH

The Easiflow Vented Cap Giant Button Head suits both 1 UNS and giant button head* attachment – a combination Long Stem fitting is also available.

All manufacturing process, materials used and the internal components of the PLI-EFLF-GBH are the same as PLI-EFLF fitting, The only difference is the addition of the GBH groove.

n.b. (The giant button head groove reduces the pressure rating of the fitting)

PART NUMBERS

PLI-EFLF-GBH1
PLI-EFLF-GBH12
PLI-EFLF-GBH14
PLI-EFLF-GBH18
PLI-EFLF-GBH34
PLI-EFLF-GBH38

AS 1210



Cavity Plug

PART NO: PLI-CP

PART NUMBER

PLI-CP

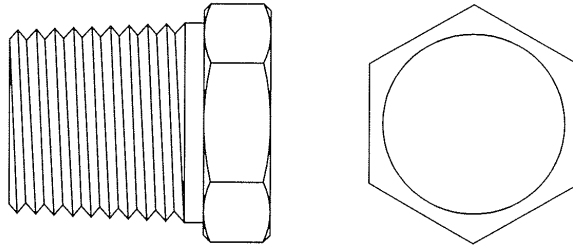

CAVITY PLUG		
PART#	THREAD SIZE	MATERIAL
PLI-CP1	1" NPT	316 SS
PLI-CP34	3/4" NPT	316 SS
PLI-CP12	1/2" NPT	316 SS
PLI-CP38	3/8" NPT	316 SS
PLI-CP14	1/4" NPT	316 SS
PLI-CP18	1/8" NPT	316 SS
PLI-CP12-SAF	1/2" NPT	UNS 31803 (Duplex)
PLI-CP14-SAF	1/4" NPT	UNS 31803 (Duplex)
PLI-CP1-SAF	1" NPT	UNS 31803 (Duplex)
PLI-CP34-SAF	3/4" NPT	UNS 31803 (Duplex)
PLI-CP38-SAF	3/8" NPT	UNS 31803 (Duplex)

OPTIONS: Alternate configurations, Threads, Materials and Plating are available on request.

PROPRIETARY NOTICE:

THIS DATA AND THE INFORMATION CONTAINED HEREIN ARE THE PROPERTY OF PRESSURE LUBE INTERNATIONAL AND SHALL NOT BE USED OR REPRODUCED OR DISCLOSED FOR ANY PURPOSE WITHOUT THE EXPRESS CONSENT OF PRESSURE LUBE INTERNATIONAL.



ON LINE VALVE LUBRICATION & SEALING
 23 JACKSON STREET, BASSENDEAN
 WESTERN AUSTRALIA 6054
 PHONE: +61-8-9379 1200 FAX: 61-8-9279 9929

TITLE: PL CAVITY PLUG

DRAWING NUMBER: PLI-CP

DRAWN BY: DAVID BRAMLEY

© COPYRIGHT

DATE:3/5/05



Packing Glands

PART NO: PLI-PG

Manufactured to order; different configurations, materials & plating available on request.

PART NUMBER

PLI-PG

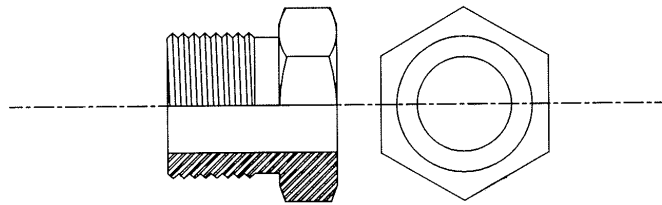

PACKING GLAND	
PART #	PLI-PG
OPTIONS : Manufactured To Order Different Configurations, Materials and Plating are Available on Request	

Junk Ring

PART NO: PLI-JR

The Junk Ring is manufactured to order with different configurations, materials and plating available on request.

PART NUMBER

PLI-JR

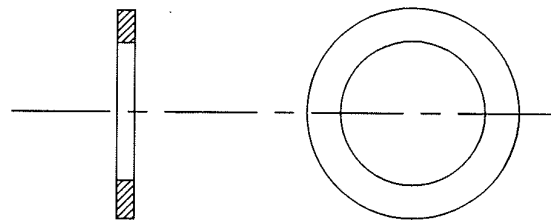

JUNK RINGS	
PART #	PLI-JR
OPTIONS : Manufactured To Order Different Configurations, Materials and Plating are Available on Request	

Body Bleed Fitting

PART NO: **PLI-BB**

The B.B.F. is used to drain the body cavity pressure.

PART NUMBER

PLI-BB

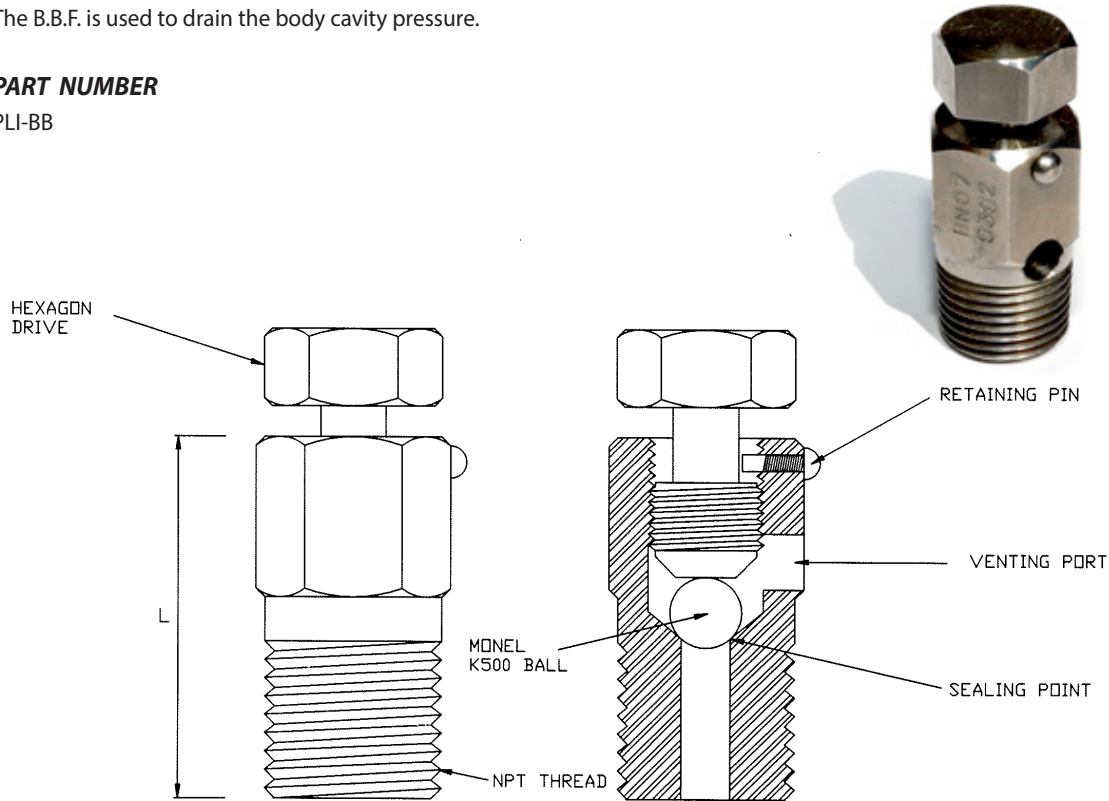

BODY BLEEDER FITTING					
PART#	THREAD SIZE	MATERIAL	HEX SIZE	L	BALL
PLI-BB112	1 1/2" NPT	316 SS	2"	2 5/8"	Monel K500
PLI-BB114	1 1/4" NPT	316 SS	1 3/4"	2 1/2"	Monel K500
PLI-BB1	1" NPT	316 SS	1 5/16"	2 7/16"	Monel K500
PLI-BB34	3/4" NPT	316 SS	1 1/8"	1 3/4"	Monel K500
PLI-BB12	1/2" NPT	316 SS	7/8"	1 5/8"	Monel K500
PLI-BB38	3/8" NPT	316 SS	7/8"	1 5/8"	Monel K500
PLI-BB14	1/4" NPT	316 SS	7/8"	1 5/8"	Monel K500

OPTIONS: Alternative configurations, threads, materials (UNS S31803 - Duplex) and plating are available on request.

PROPRIETARY NOTICE:

THIS DATA AND THE INFORMATION CONTAINED HEREIN ARE THE PROPERTY OF PRESSURE LUBE INTERNATIONAL AND SHALL NOT BE USED OR REPRODUCED OR DISCLOSED FOR ANY PURPOSE WITHOUT THE EXPRESS CONSENT OF PRESSURE LUBE INTERNATIONAL.



ON LINE VALVE LUBRICATION & SEALING
 23 JACKSON STREET, BASSENDEAN
 WESTERN AUSTRALIA 6054
 PHONE: +61-8-9379 1200 FAX: 61-8-9279 9929

TITLE: PLI BODY BLEED FITTING

DRAWING NUMBER: **PLI-BB**

DRAWN BY: DAVID BRAMLEY

© COPYRIGHT

DATE: 3/5/05



Internal Check Fitting

PART NO: PLI-ICF

The I.C.F. is installed before the lube fitting.

PART NUMBER

PLI-ICF

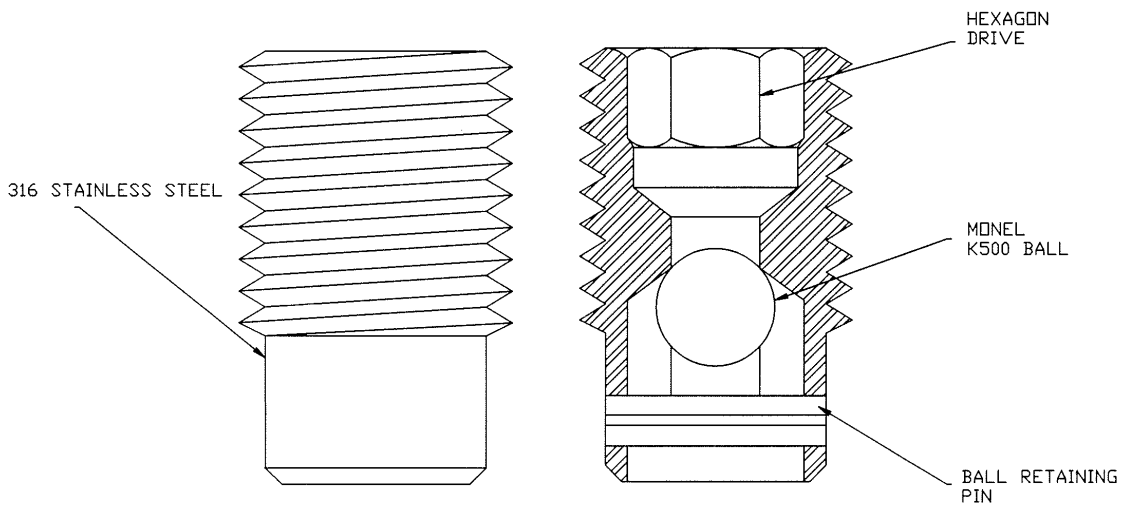

SINGLE (SPRING LOADED) BALL CHECK FITTING	
PART#	THREAD SIZE
PLI-IC1	1" - 8
PLI-IC78	7/8" - 9
PLI-IC34	3/4" - 10
PLI-IC12	1/2" - 13
PLI-IC14	1/4" - 20

OPTIONS: Alternate configurations, Threads, Materials and Plating are available on request.

PROPRIETARY NOTICE:
THIS DATA AND THE INFORMATION CONTAINED HEREIN ARE THE PROPERTY OF PRESSURE LUBE INTERNATIONAL AND SHALL NOT BE USED OR REPRODUCED OR DISCLOSED FOR ANY PURPOSE WITHOUT THE EXPRESS CONSENT OF PRESSURE LUBE INTERNATIONAL.

Packing Injection Fitting

PART NO: PLI-PIF

The P.I.F. is installed to the stem of a valve to assist in stem sealing.

PART NUMBER

PLI-PIF

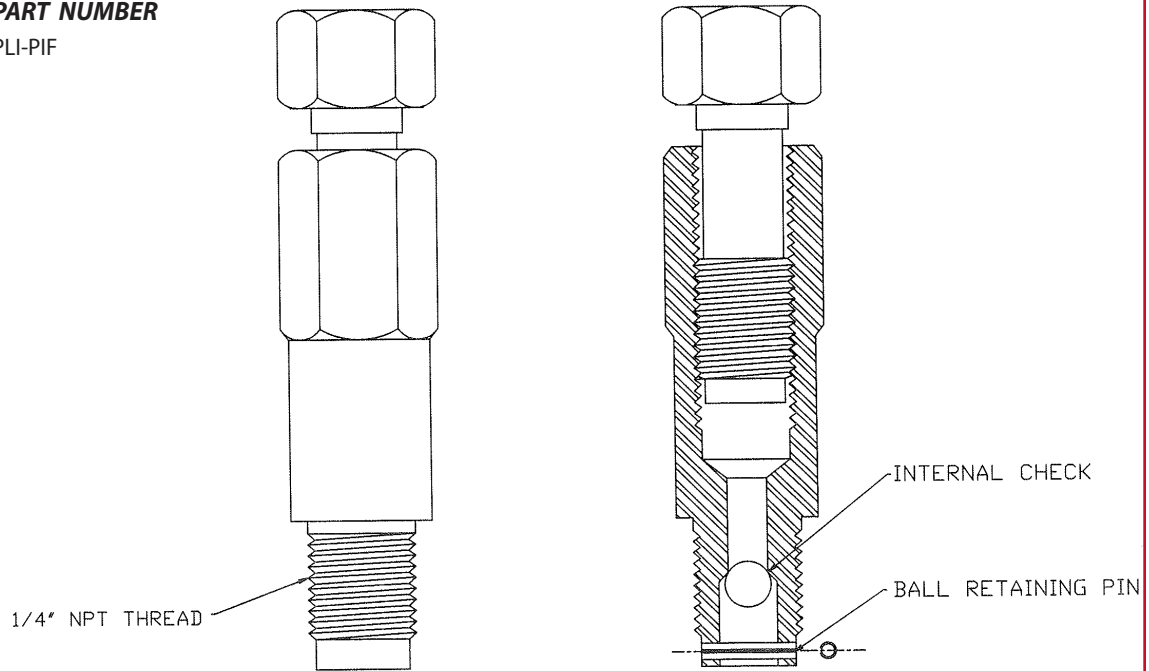

PACKING INJECTION FITTING	
PART#	PLI-PIF
PLI-PIF14	1/4" MPT
PLI-PIF38	3/8" MPT
PLI-PIF38	1/2" MPT
Material: 316 SS	
Plating: Zn + Cr ₂ O ₄	
<i>OPTIONS:</i> Alternative material (S1214 plated) grades, plating and attachment threads available on request	

THIS DATA AND THE INFORMATION CONTAINED HEREIN ARE THE PROPERTY OF PRESSURE LUBE INTERNATIONAL AND SHALL NOT BE USED OR REPRODUCED OR DISCLOSED FOR ANY PURPOSE WITHOUT THE EXPRESS CONSENT OF PRESSURE LUBE INTERNATIONAL.



ON LINE VALVE LUBRICATION & SEALING
23 JACKSON STREET, BASSENDEAN
WESTERN AUSTRALIA 6054
PHONE: +61-8-9379 1200 FAX: 61-8-9279 9929

TITLE: PL PACKING INJECTION FITTING

DRAWING NUMBER: PLI-PIF

DRAWN BY: DAVID BRAMLEY

© COPYRIGHT

DATE: 3/5/05



PRESSURELUBE
INTERNATIONAL

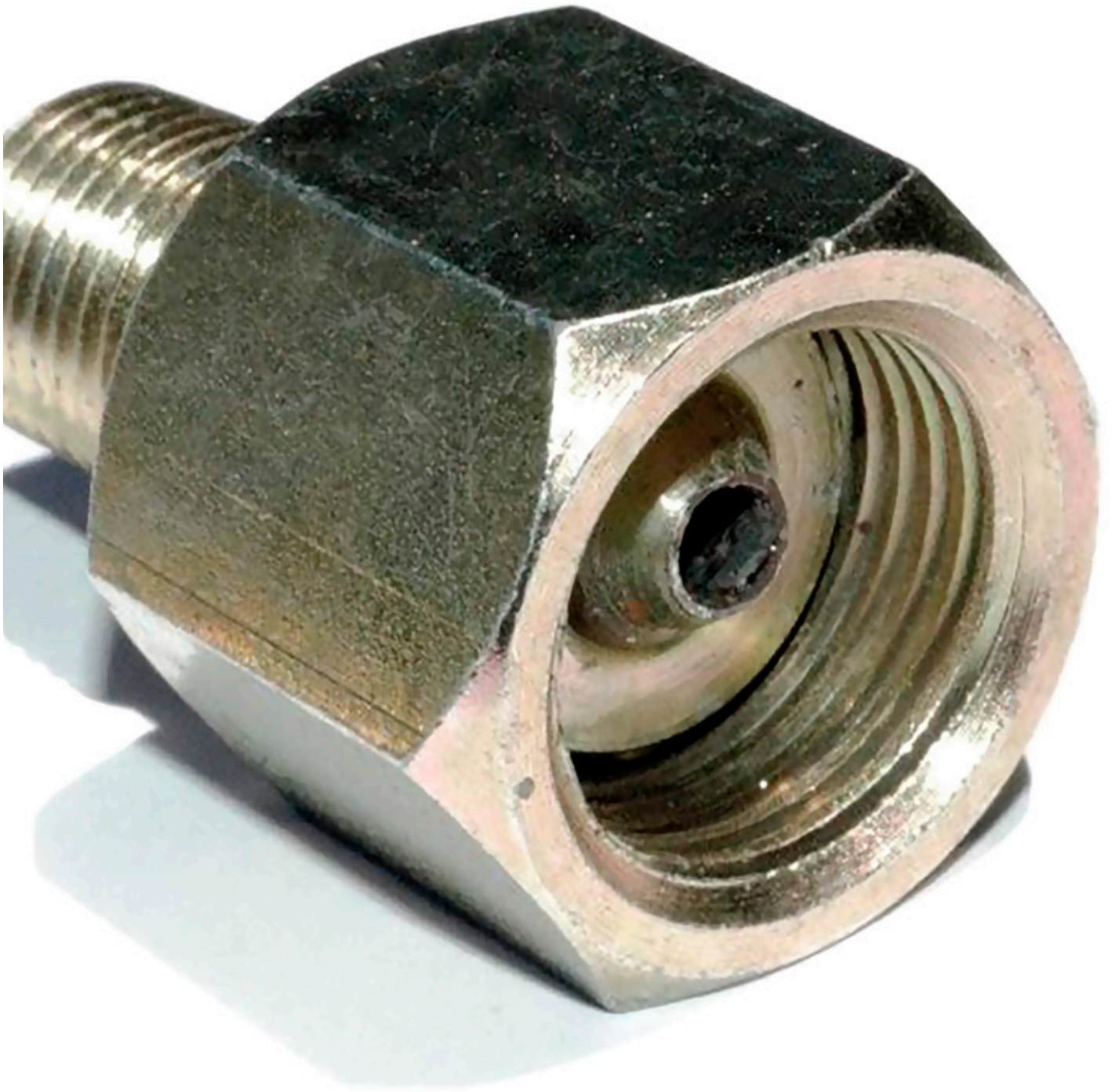



Company | Capabilities

ON-LINE VALVE LUBRICATION AND SEALING SERVICE

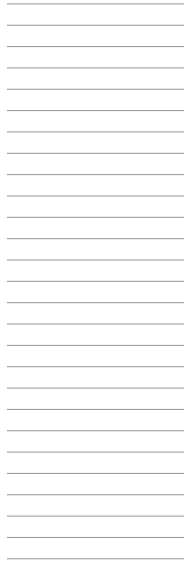
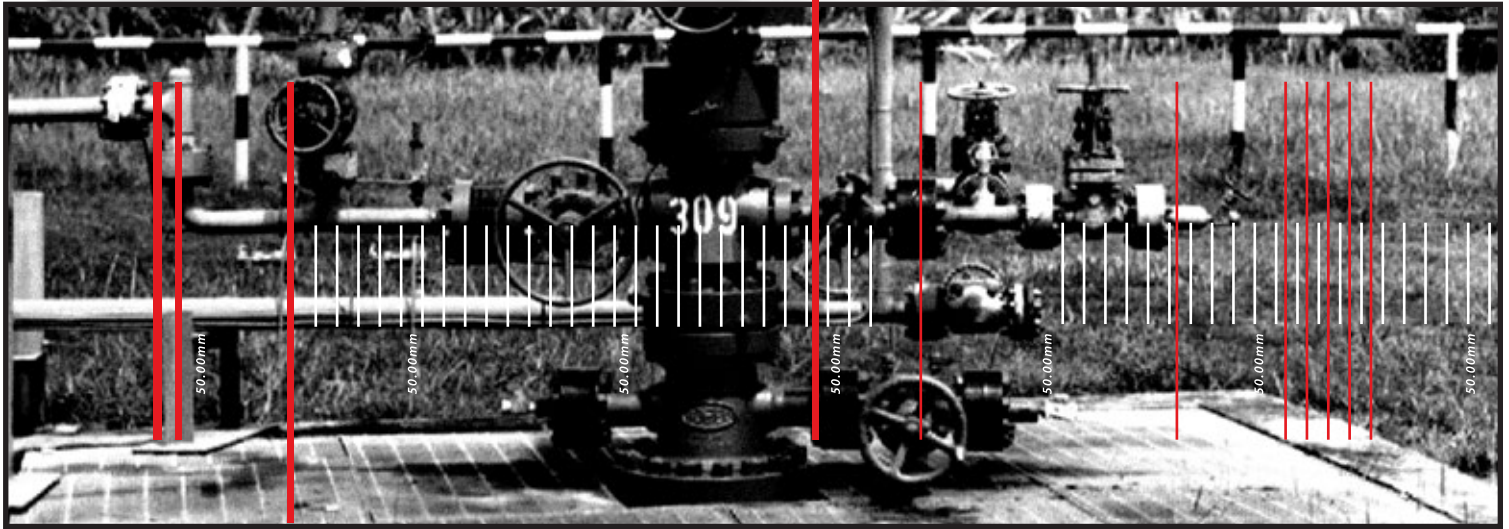

Adaptors





Lube Adaptor

PART NO: PLI-LA

The PLI Lube Adapter is used on the end of a lube whip hose or safety vent coupler for lube fitting connection

PART NUMBER

PLI-LA

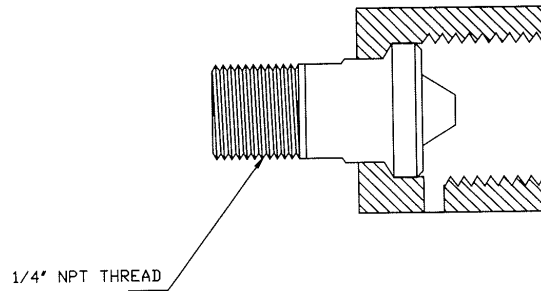

LUBE ADAPTOR	
PART #	TO FIT THREAD
PLI-LA114	1" - 14 UNS
PLI-LA78	7/8" - 14 UNF
PLI-LA34-16	3/4" - 16 UNF
STANDARD MATERIAL : S1214	
PLATING : Zn + Cr ₂ O ₄	

PROPRIETARY NOTICE:

THIS DATA AND THE INFORMATION CONTAINED HEREIN ARE THE PROPERTY OF PRESSURE LUBE INTERNATIONAL AND SHALL NOT BE USED OR REPRODUCED OR DISCLOSED FOR ANY PURPOSE WITHOUT THE EXPRESS CONSENT OF PRESSURE LUBE INTERNATIONAL.



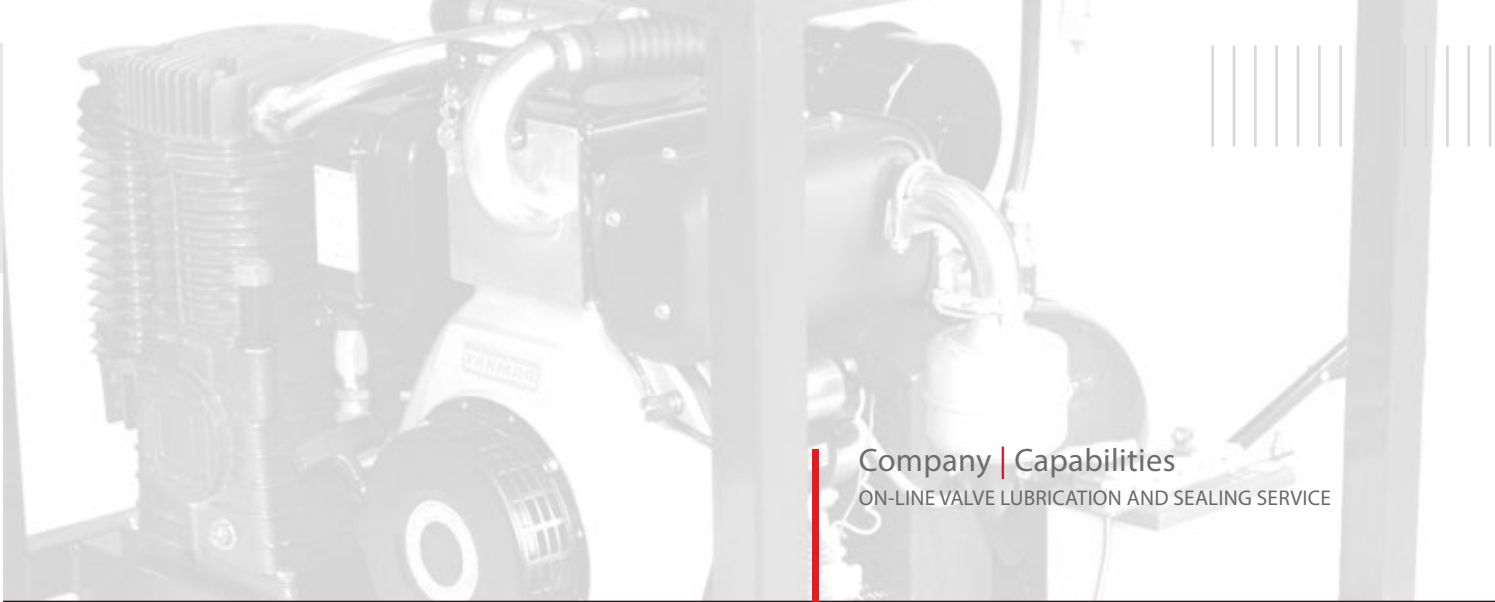

Company | Capabilities

ON-LINE VALVE LUBRICATION AND SEALING SERVICE

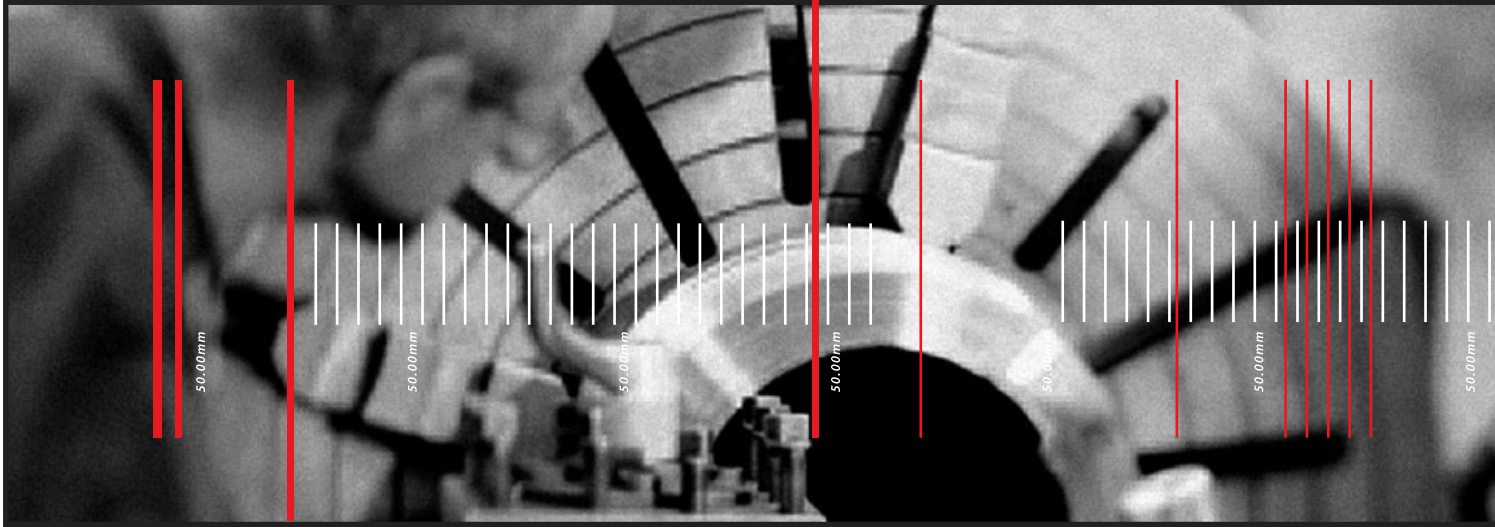

Safety Tools

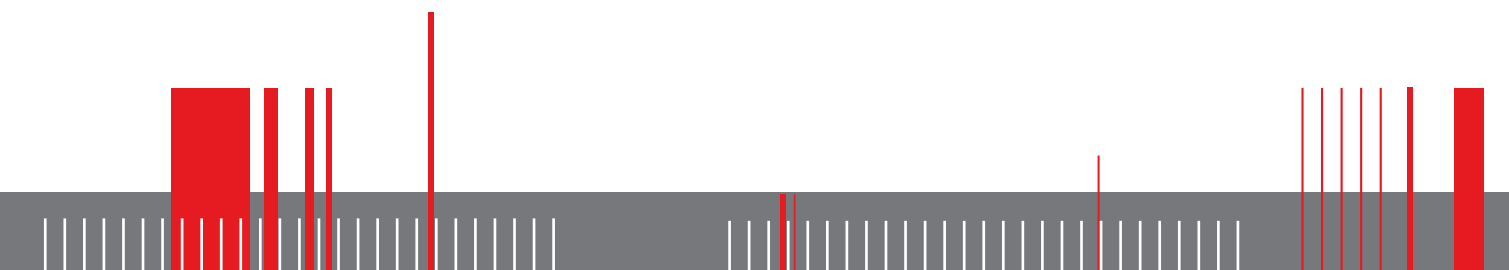



PRESSURELUBE
INTERNATIONAL

Pressure Relief Tool

PART NO: PLI-PRT

The PLI Pressure Relief Tool is used to screw onto the lube fitting to vent pressure.

PART NUMBER

PLI-PRT

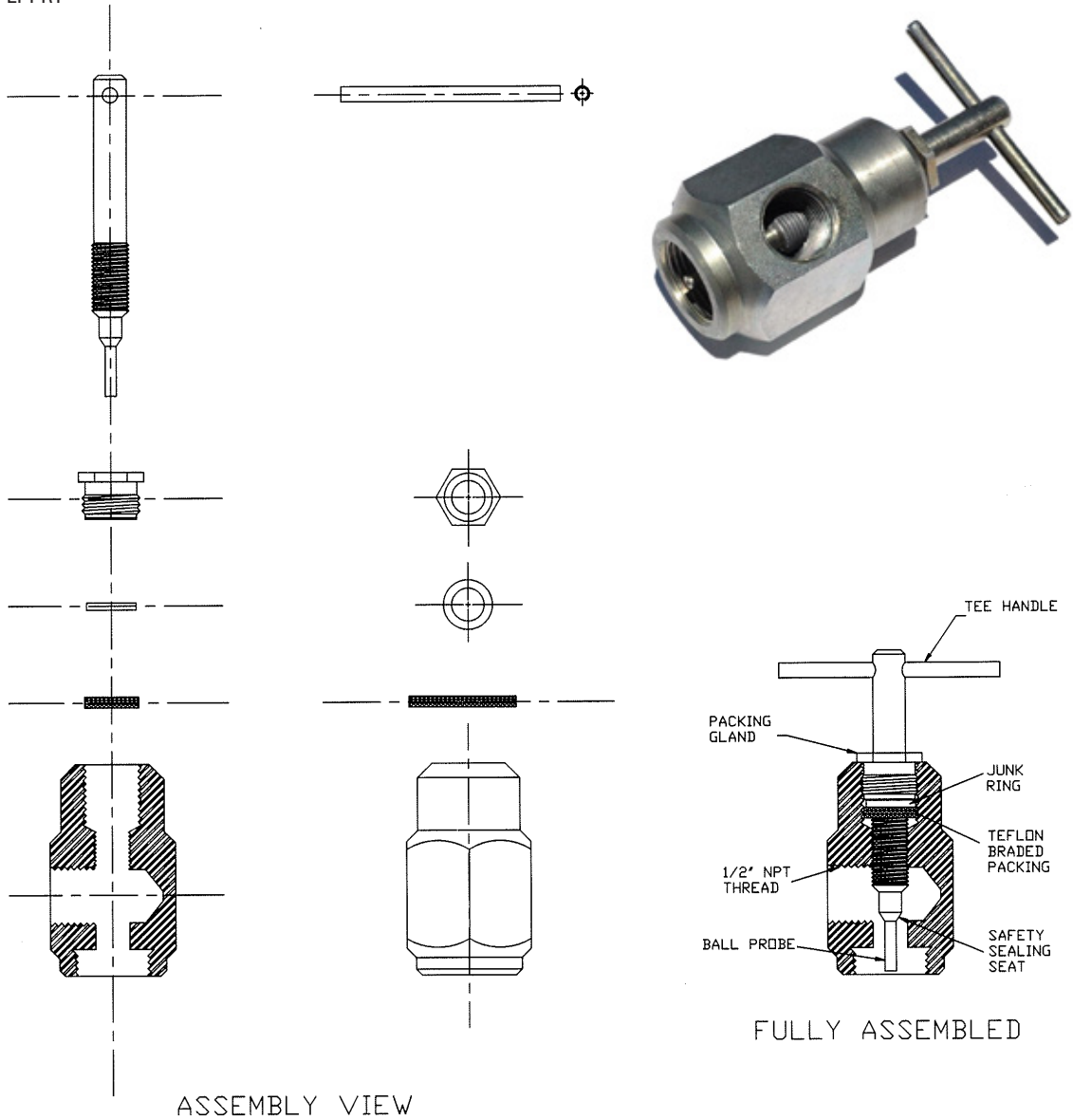

PRESSURE RELIEF TOOL	
MATERIAL	S1214
PLATING	Zn + Cr ₂ O ₄
STANDARD THREAD	1"-14 UNS
OPTIONS : Alternate Thread Sizes Available on Request	

PROPRIETARY NOTICE:
THIS DATA AND THE INFORMATION CONTAINED HEREIN ARE THE PROPERTY OF
PRESSURE LUBE INTERNATIONAL AND SHALL NOT BE USED OR REPRODUCED OR DISCLOSED
FOR ANY PURPOSE WITHOUT THE EXPRESS CONSENT OF PRESSURE LUBE INTERNATIONAL.



PRESSURELUBE
INTERNATIONAL

ON LINE VALVE LUBRICATION & SEALING
23 JACKSON STREET, BASSENDEAN
WESTERN AUSTRALIA 6054
PHONE: +61-8-9379 1200 FAX: 61-8-9279 9929

TITLE: PLI PRESSURE RELIEF TOOL

DRAWING NUMBER: PLI-PRT

DRAWN BY: DAVID BRAMLEY

© COPYRIGHT

DATE: 3/5/05

Leak Lock Fitting

PART NO: PLI-LLF

The L.L.F. connects to a giant button head fitting. It is used as a lube adapter or to seal a leaking giant button head fitting.

PART NUMBER

PLI-LLF

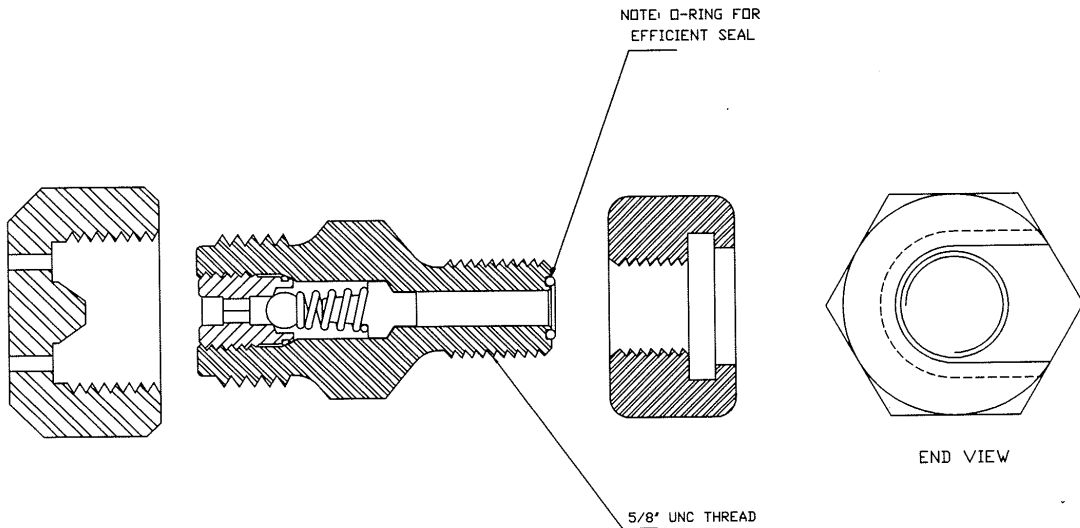
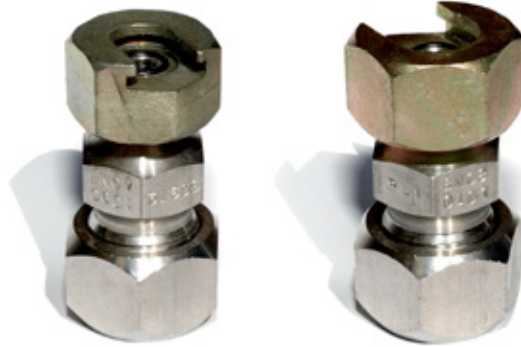

LEAK LOK FITTING	
PART #	TO SUIT
PLI-LL1	GIANT BUTTON HEAD
PLI-LL2	STANDARD BUTTON HEAD
<i>NUT :</i>	<i>MATERIAL :</i> S1214 <i>PLATING :</i> Zn + Cr ₂ O ₄
<i>FITTING :</i> AS PER STANDARD EASY FLOW FITTING	

PROPRIETARY NOTICE:

THIS DATA AND THE INFORMATION CONTAINED HEREIN ARE THE PROPERTY OF PRESSURE LUBE INTERNATIONAL AND SHALL NOT BE USED OR REPRODUCED OR DISCLOSED FOR ANY PURPOSE WITHOUT THE EXPRESS CONSENT OF PRESSURE LUBE INTERNATIONAL.



ON LINE VALVE LUBRICATION & SEALING
 23 JACKSON STREET, BASSENDEAN
 WESTERN AUSTRALIA 6054
 PHONE: +61-8-9379 1200 FAX: 61-8-9279 9929

TITLE: PLI LEAK LOCK FITTING

DRAWING NUMBER: PLI-LL

DRAWN BY: DAVID BRAMLEY

© COPYRIGHT

DATE:3/5/05



PRESSURELUBE
INTERNATIONAL



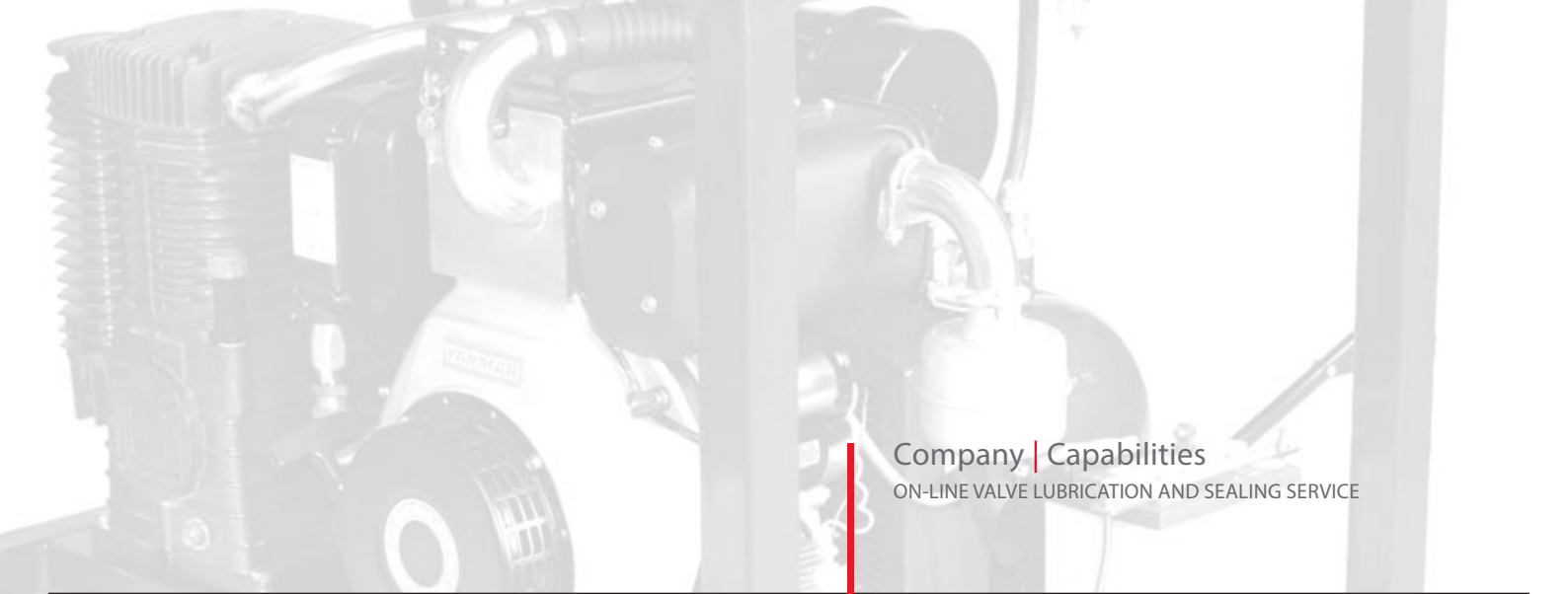

Company | Capabilities

ON-LINE VALVE LUBRICATION AND SEALING SERVICE

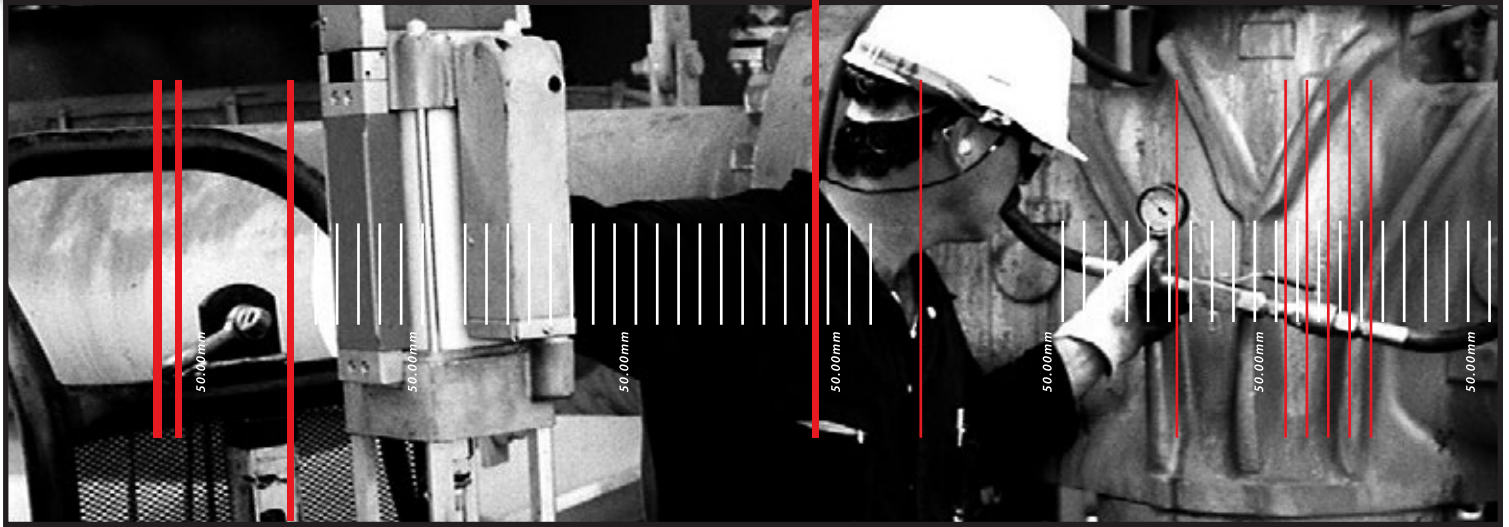

Diesel Air Compressor Pumps & Equipment

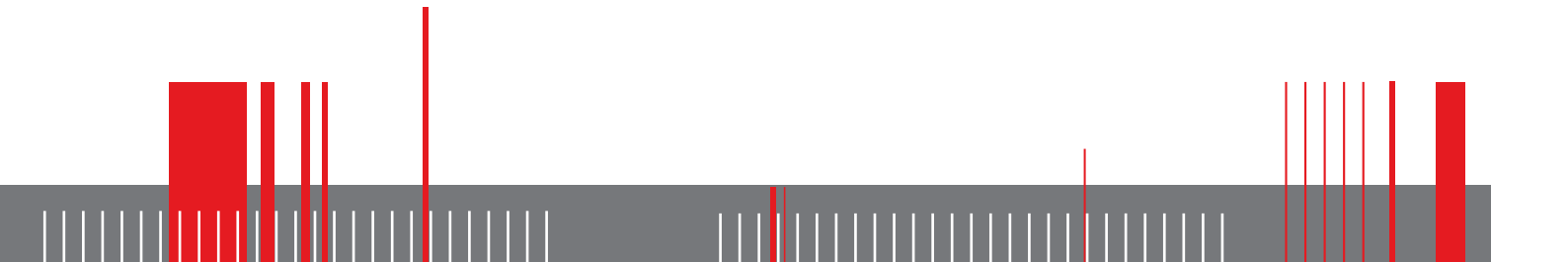



Flush Pump

PART NO: PLI-FP-SS-TT

The PLI Flush Pump with stainless steel tank and trolley holds 28 litres of Liquid Valve Flush, used for injecting Liquid Valve Flush into the valve for cleaning internal lube ports & components prior to lubing.

PART NUMBER

PLI-FP-SS-TT

SPARE PARTS

- | | |
|----|--------------------------------------|
| 1 | All Stainless Steel Trolley and Tank |
| 2 | Filter Regulator |
| 3 | Control Valve for Air Motor On/Off |
| 4 | Flush Discharge Hose Connection |
| 5 | Pressure Release Valve to Tank |
| 6 | 10,000 PSI Liquid Pump |
| 7 | Pneumatic Tyres |
| 8 | Air Motor Filter |
| 9 | Filler |
| 10 | 28 Litre Tank |



Bucket Pump

PART NO: PLI-BP-LW

The PLI Bucket pump (lightweight) will deliver up to 8,500psi. It is used for the injection of sealant and lubrication into valves.

The PMV 8,500psi Bucket Pump is designed as a compact lightweight, high pressure unit that is easily carried in a helicopter. Good for servicing up to 12" ball valves.

PART NUMBER

PLI-BP-LW

SPARE PARTS

1	Steel Powder Coated Trolley
2	Air Motor
2.1	Spare Part
3	Lube Discharge Hose Connection
4	Pressure Release
5	Pump Tube
5.1	Spare Part
6	Follower Plate
7	Connect Air Hose to Remove Bucket
8	Filter Regulator
9	Air Ram
10	Pneumatic Tyre





PM3 Pump - Premium

PART NO: PLI-PM3-7PSI PRM

The Powermaster 3 - 7,500psi high pressure lubrications and injecting lubricant or sealant into any size Gate, Plug or Ball Valve. It features the same PM3 lubrication pump arrangement as the Standard Model but includes additional features that provide improved life cycle & functionality. Features: Heavy duty, compact frame, HD pneumatic wheels, Pneumatic lift ram, Air filter lubricator, 2 sets of Quick connect couplings, Lincoln Power Master 3 Air Motor with Full 6" stroke, 4.5m high pressure hose (1,000 bar wp). 1/2" Whip hose assembly with Universal Swivel, safety tee for high pressure bleed off, 10,000psi gauge and ball valve, 316SS Fittings & Tubing, Built in counter for accurate measurement of lube/sealant, Blow off valve to the follower plate for easy removal of the bucket, Safety guarding on the trolley.

PART NUMBER

PLI-PM3-7PSI

SPARE PARTS

1.1	Power Valve
1.2	Pilot Bar
1.3	Muffler Filter
1.4	Air Motor Complete
2	Counter with Reset to count air motor strokes from the lube pump
3	High Pressure Safety Tee with needle valve for pump and line pressure release
3.1	Needle Valve - Pressure Release
3.2	Quick Connector
4	Pump Tube
5	Follower Plate O-Ring
5.1	Air Bleed Valve
6	Solid Trolley Frame powder coat painted
7	Safety Guard
8	Air filter / regulator / lubricator (105psi max air pressure)
9	Air Supply In
10	Pneumatic Air Ram
11	Blow off valve to the follower plate for removing the bucket
12	Up/Down air control valve for the air ram on the lube pump
13	On/Off valve for the air motor to the lube pump
14	Identification Tag
15	Pneumatic Tyres

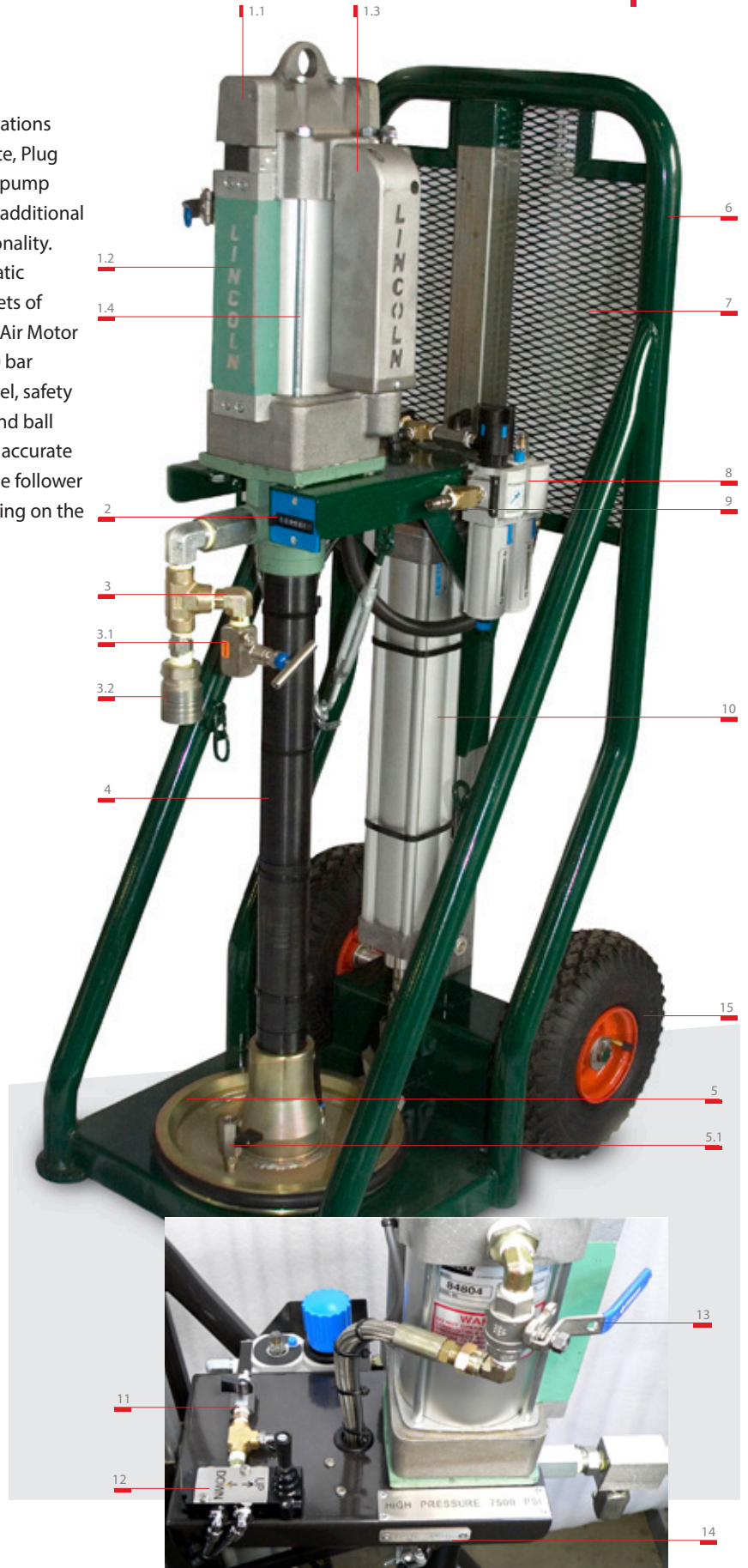

DIESEL AIR COMPRESSOR PUMPS & EQUIPMENT

PM3 Pump

PART NO: PLI-PM3-14PSI

The PLI Powermaster III - 14,000 psi, high pressure lubricating and sealing pump.
This unit is the same frame height as the PM3 7,500 but has a 14,000 PSI lube/sealant pump for the extreme high pressure service work - good for servicing any size valve.

SPARE PARTS

- | | |
|-----|---|
| 1.1 | Power Valve |
| 1.2 | Pilot Bar |
| 1.3 | Muffler Filter |
| 1.4 | Air Motor Complete |
| 2 | Counter with Reset to count air motor strokes from the lube pump |
| 3 | High Pressure Safety Tee with needle valve for pump and line pressure release |
| 3.1 | Needle Valve - Pressure Release |
| 3.2 | Quick Connector |
| 4 | Pump Tube |
| 5 | Follower Plate O-Ring |
| 5.1 | Air Bleed Valve |
| 6 | Solid Trolley Frame powder coat painted |
| 7 | Safety Guard |
| 8 | Air filter / regulator / lubricator (105psi max air pressure) |
| 9 | Air Supply In |
| 10 | Pneumatic Air Ram |
| 11 | Blow off valve to the follower plate for removing the bucket |
| 12 | Up/Down air control valve for the air ram on the lube pump |
| 13 | On/Off valve for the air motor to the lube pump |
| 14 | Identification Tag |
| 15 | Pneumatic Tyres |

PART NUMBER
PLI-PM3-14PSI

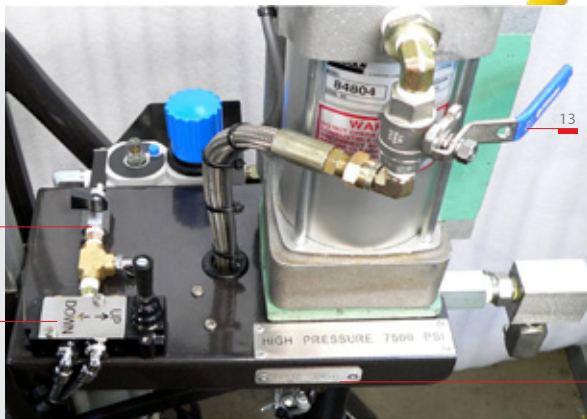
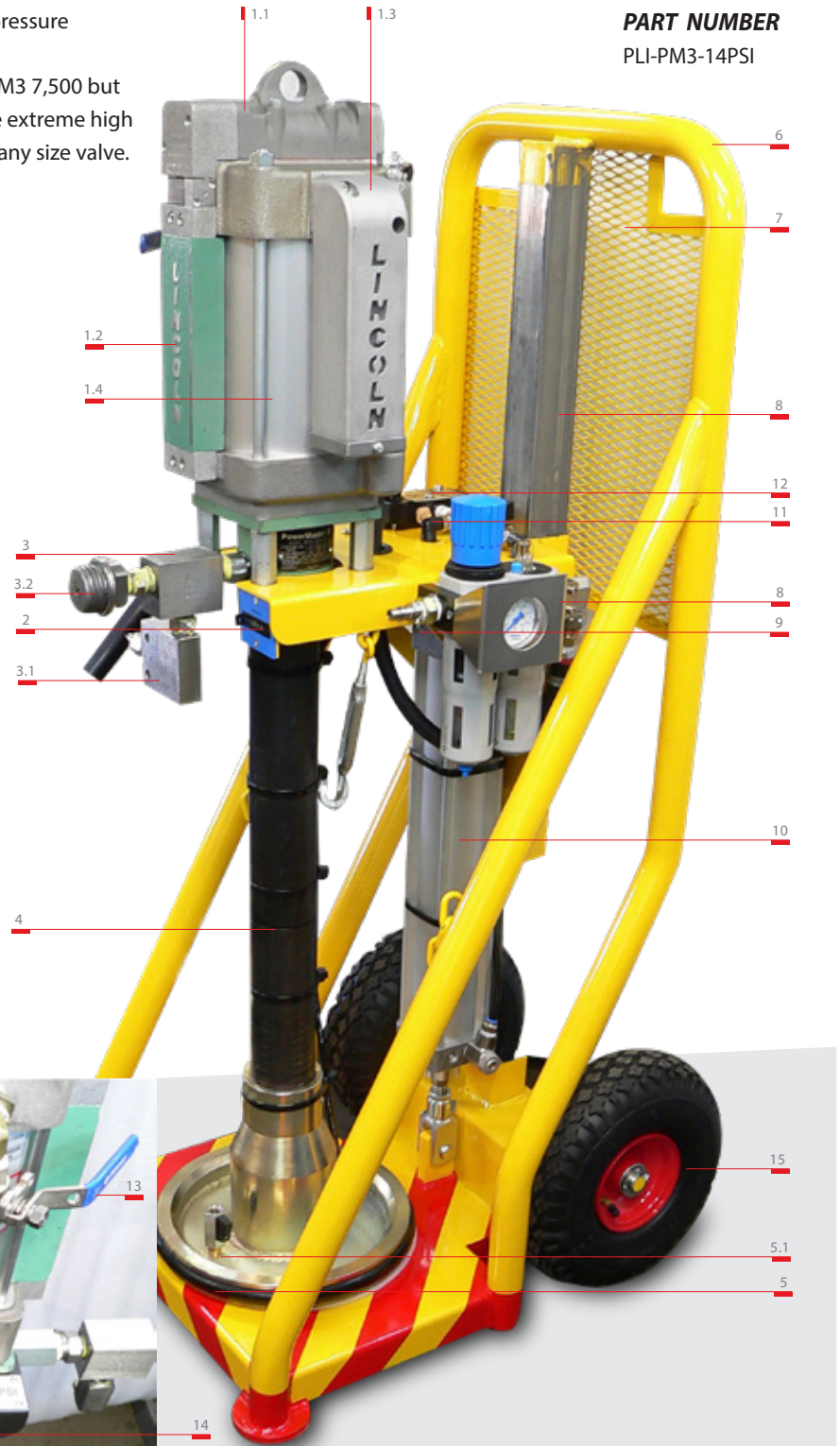



Aluminium Trolley

PART NO: PLI-AL-T

Sturdy Aluminium Trolley, 4 pneumatic wheels for carrying service equipment throughout process plant. Complete with tie-downs, tool tray and air hose reels.

PART NUMBER

PLI-AL-T

SPARE PARTS

- | | |
|---|---|
| 1 | Aluminium Trolley Powder Coated |
| 2 | Pneumatic Tyres |
| 3 | Air Supply Hose Reel Complete |
| 4 | Lube Supply Hose Reel Complete with Hose |
| 5 | Flush Supply Hose Reel Complete with Hose |

Note: Pumps are not included.

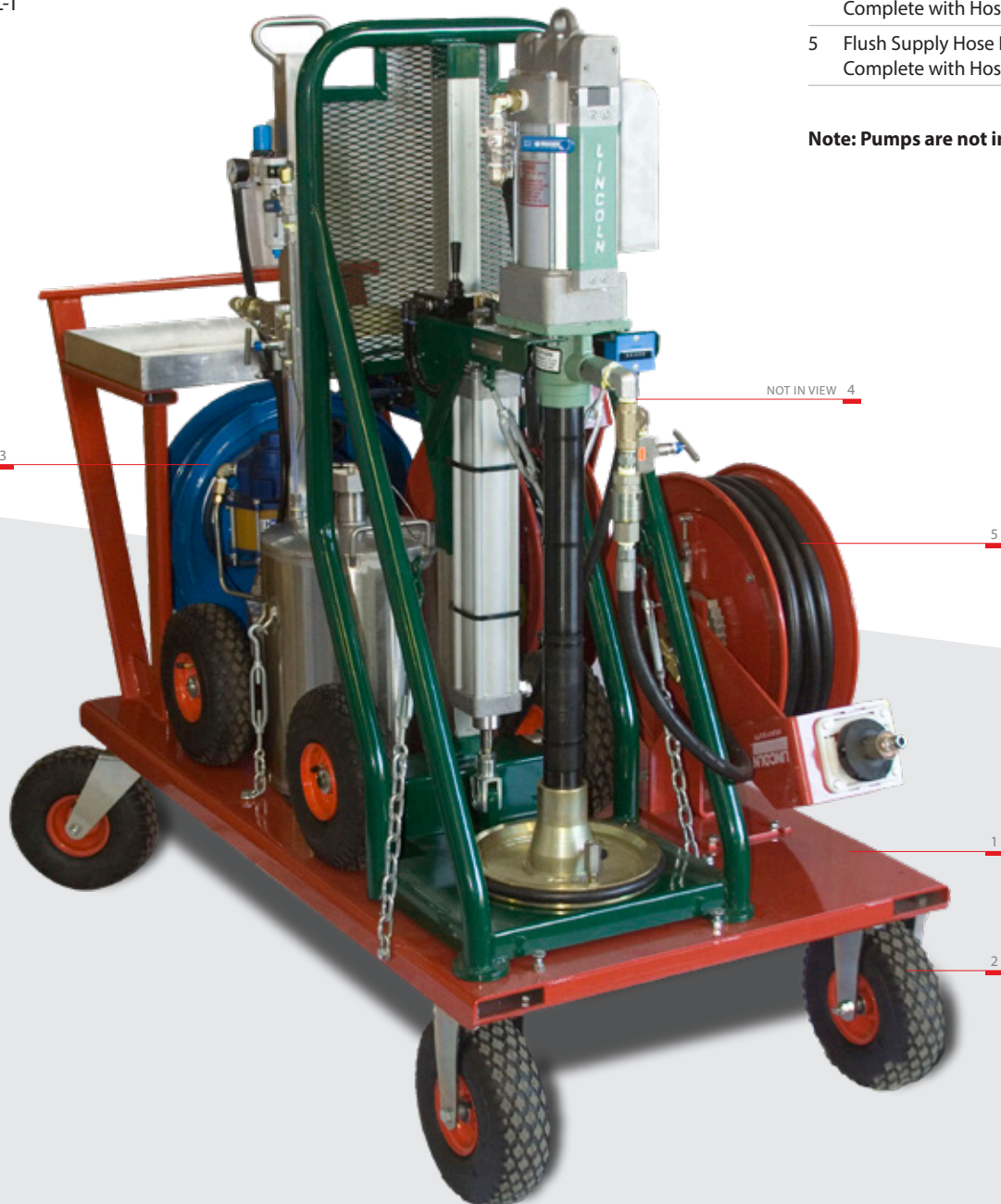

Open Skid Unit

PART NO: PLI-OSU

Open Skid Unit with Power Master 3 7,500psi Lubrication Sealant Pump, 38 litre tank with 10,000 PSI, liquid flush pump, two supply hose reels and full pneumatic control cabinet.

Designed for the back of a 4x4 pickup or a light truck. All equipment is air operated and assembled on a heavy duty steel protective frame.

PART NUMBER

PLI-OSU

Front View



SPARE PARTS

1	Complete Air Motor
1.1	Power Valve Seals
1.2	Pilot Bar Seals
1.3	Muffler Filter
1.4	Air Motor Seals
2	Needle Valve Lube Pressure Release
3	Pneumatic Air Ram
4	Liquid Flush Reel Complete with Hose
5	Lube / Seal Reel Complete with Hose
6	Complete Control Cabinet
7	Follower Plate O-Ring
8	Mini Ball Valve
9	Liquid Flush Pump
10	Flush Tank Level Indicator
11	Pump Tube Complete
11.1	Pump Tube Seals
12	Air Supply Hose for Control Box



Rear View

SPARE PARTS

- 4 Liquid Flush Reel Complete with Hose
- 9 Liquid Flush Pump
- 12 Air Supply Hose for Control Box

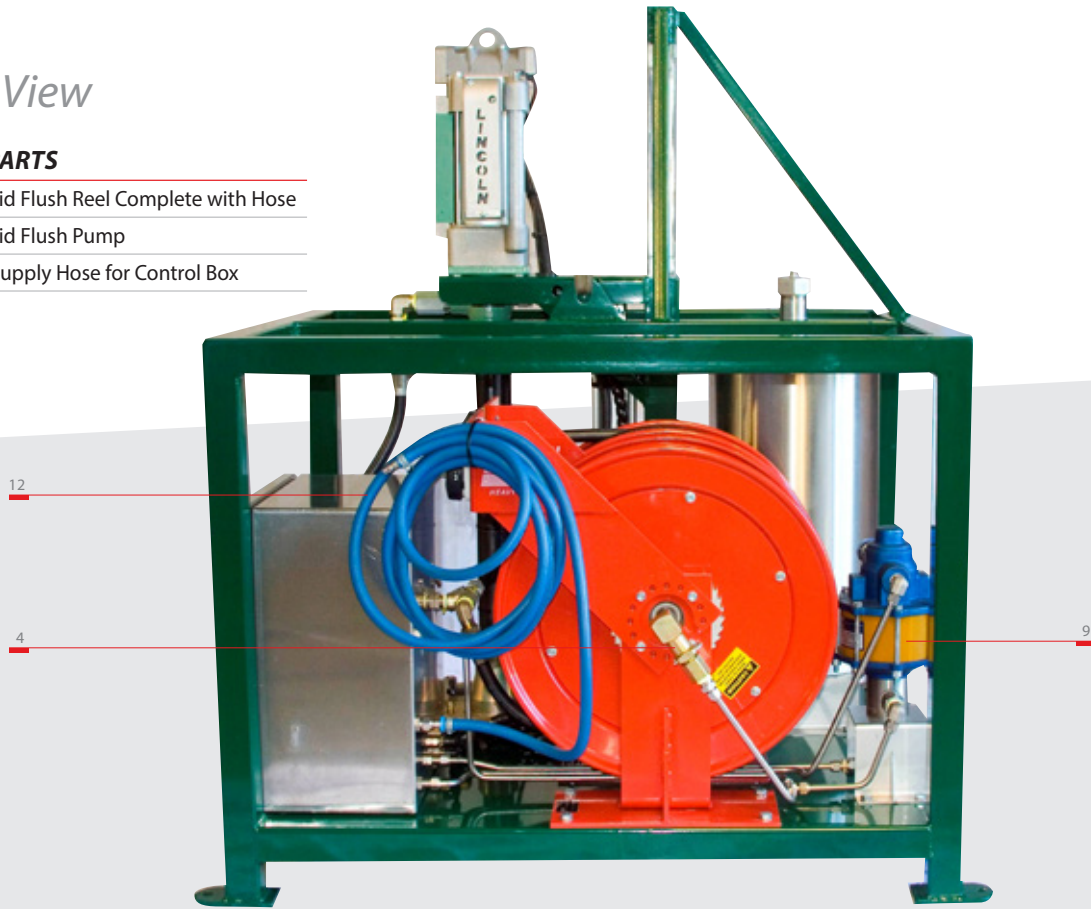

Open Skid Unit Control Cabinet

SPARE PARTS

- 2 Air Filter Regulator
- 3 Adjustable Oil Lubricator
- 5 Air Control Valve
- 6 Pneumatic Counter with Reset
- 7 Lube Pressure Gauge
- 8 On/Off Valve for Lube Air Motor
- 9 Bucket Blowoff Valve
- 10 On/Off Valve for Flush Pump
- 11 Flush Pressure Relief Valve
- 12 Flush Pressure Gauge



Open Skid Unit

PART NO: PLI-OSU-1

The Open Skid Unit is designed and used for pumping Lubricant/Sealant and Liquid Flush into Well Head, Pipeline, and process plant valves in the Oil & Gas industry.

The OSU unit consists of two Lincoln PM3 7,500psi Lubrication/Sealant Pumps, Stainless Steel 38 litre liquid tank with a 10,000psi liquid flush pump, 3 supply hose reels complete with 15m hoses and safety whips, 30 CFM, 10HP, Electric and Pull Start Diesel Powered Air Compressor with a 53 litre air receiver, All this is controlled by a full pneumatic control cabinet.

The OSU is designed for the back of a 4x4 pickup, light truck, or a trailer. All equipment is air operated and assembled on a heavy-duty steel Powder Coated protective frame. The frame size and pumps can be modified to suit applications.





PRESSURELUBE
INTERNATIONAL

Open Skid Unit

PART NO: PLI-SKID-6

The Custom Open Skid Unit is designed and used for pumping Lubricant/Sealant and Liquid Flush into Well Head, Pipeline and process plant valves in the Oil & Gas industry. The frame size and pumps can be modified to suit application.

The COSU consists of two Lincoln PM3 14,000psi Lubrication/Sealant Pumps regulated down to a maximum 10,000psi , Stainless Steel 38 litre liquid tank with a 10,000psi stainless steel liquid flush pump, 3 supply hose reels complete with 15m hoses and safety whips, 30 CFM, 10HP Diesel Powered Air Compressor with a 53 litre air receiver, All this is controlled by a full pneumatic control cabinet.

The COSU is designed for the back of a 4x4 pickup, light truck or a trailer. All equipment is Air Operated and assembled on a heavy-duty steel Powder Coated protective frame.



Open Skid Unit

PART NO: PLI-OSU-7

The Custom Open Skid Unit is designed and used for pumping Lubricant/Sealant and Liquid Flush into Well Head, Pipeline and process plant valves in the Oil & Gas industry. The frame size and pumps can be modified to suit application.

The PLI-OSU-7 consists of two Lincoln PM3 7,500psi Lubrication/Sealant Pumps, Stainless Steel 38 litre liquid tank with a 10,000psi stainless steel liquid flush pump, 3 supply hose reels complete with 15m hoses and safety whips, 1 air hose reel complete with 20m of air hose and quick connector, 30 CFM, 10HP Diesel Powered Air Compressor with a 53 litre air receiver. All this is controlled by a full pneumatic control cabinet.

The PLI-OSU-7 is designed for the back of a 4x4 pickup, light truck or a trailer. All pump equipment is Air Operated and assembled on a heavy-duty steel Powder Coated protective frame.





Diesel Air Compressor (Zone 2)

PART NO: *PLI-DPAC-Z2*

ZONE 2

Diesel Powered Air Compressor, 30 CFM, 10HP, PULL start, diesel motor, 45 litre receiver, filter regulator with two quick air connectors for air hoses, all electrics are removed. Emergency and auto shut down controls, spark arrested motor. All assembled on a heavy duty protective steel frame designed to work in the dessert.

PART NUMBER

PLI-DPAC-Z2



DIESEL AIR COMPRESSOR PUMPS & EQUIPMENT

Diesel Air Compressor

PART NO: *PLI-DPAC-ES*

Electric Start

SPARE PARTS

1	Piston Air Compressor	7	Pressure Relief
2	Pull Start	8	12 Volt Battery
3	10HP Diesel Engine	9	Donaldson Air Filtration Unit
4	Quick Air Connectors	10	Air Receiver Pressure Gauge
5	Filter Regulator	11	Unloader Valve
6	Spark Arrestor		

Lifting Point

Filtered air induction system

Electric start

1

Air compressor oil filter

3

2

Compressor oil level indicator

Bolt the compressor down here

Filtered
air
induction
system

4

5

6

7

45 litre air receiver

8

Receiver drain

9

10

11



Diesel Air Compressor

PART NO: *PLI-DPAC-ES*

For pull starting. Tune the fuel on. Tune the ignition key on. Hold the decompression lever down and slowly pull the pull start handle 1 time for fuel priming, then standard pull start procedures apply.

NOTE: **Do Not** use the decompression valve to stop the engine

Fill with Diesel only

For electric starting, Tune the fuel on. Tune the key to start the engine. Leave the key in the on position when the engine is running, so the battery can be charged. When the engine is stopped, tune the key off.

Tune fuel valve. ON & OFF

Pull start

Threaded rods to assist in engine alignment and belt tensioning

Pneumatic throttle control.

To check diesel oil

To stop the engine, pull this lever out until engine has completely stopped, then tune the ignition and fuel off.



Calibrated Chart Recorder

PART NO: PLI-CCR

10,000 PSI Calibrated Chart Recorder as part of an integrity testing rig. The whole unit is mounted in a hinged door stainless steel cabinet, fully weather sealed and lockable.

PART NUMBER

PLI-CCR

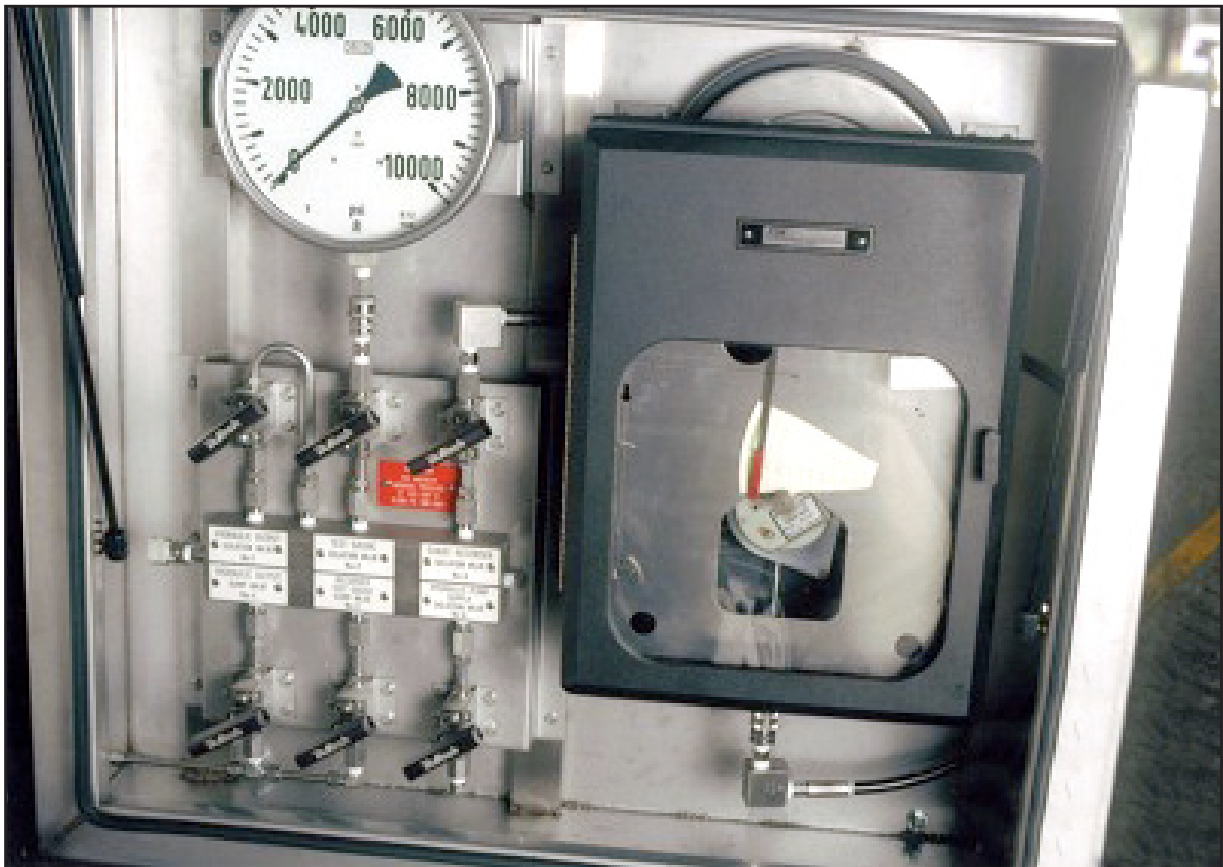



Whip Hose

PART NO: *PLI-WP*

The PLI Whip Hose is an integral part of the pump's delivery and safety feature. A short flexible high pressure hose allows the operator to step back from the valve and still have control of flow and isolation via the stainless steel ball valve. There is a universal Z-swivel with a 90 degree elbow and a LA114 lube adaptor, these items give greater flexibility when connecting to the valve. The pressure gauge indicates the delivery pressure at the lubrication fitting. This safety whip has a high pressure full flow quick connector, for easy connection/disconnection to the supply hose.

PART NUMBER

PLI-WP

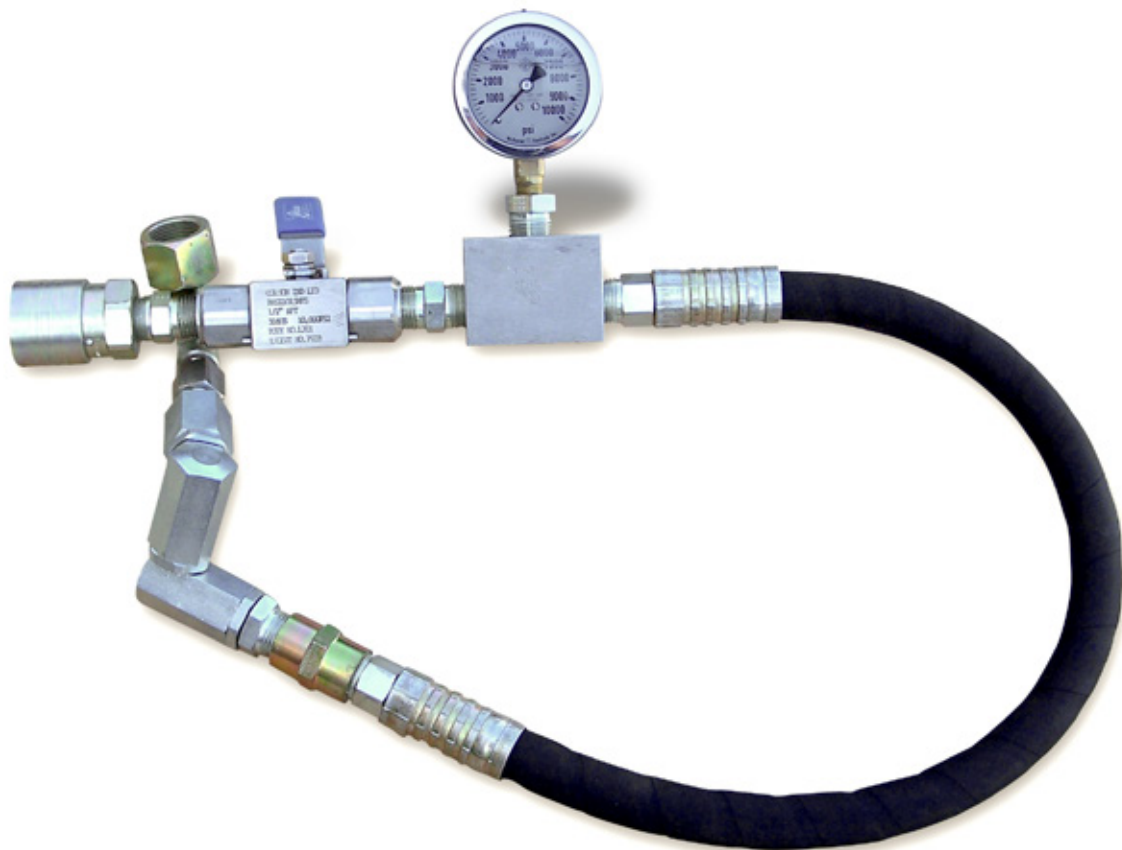

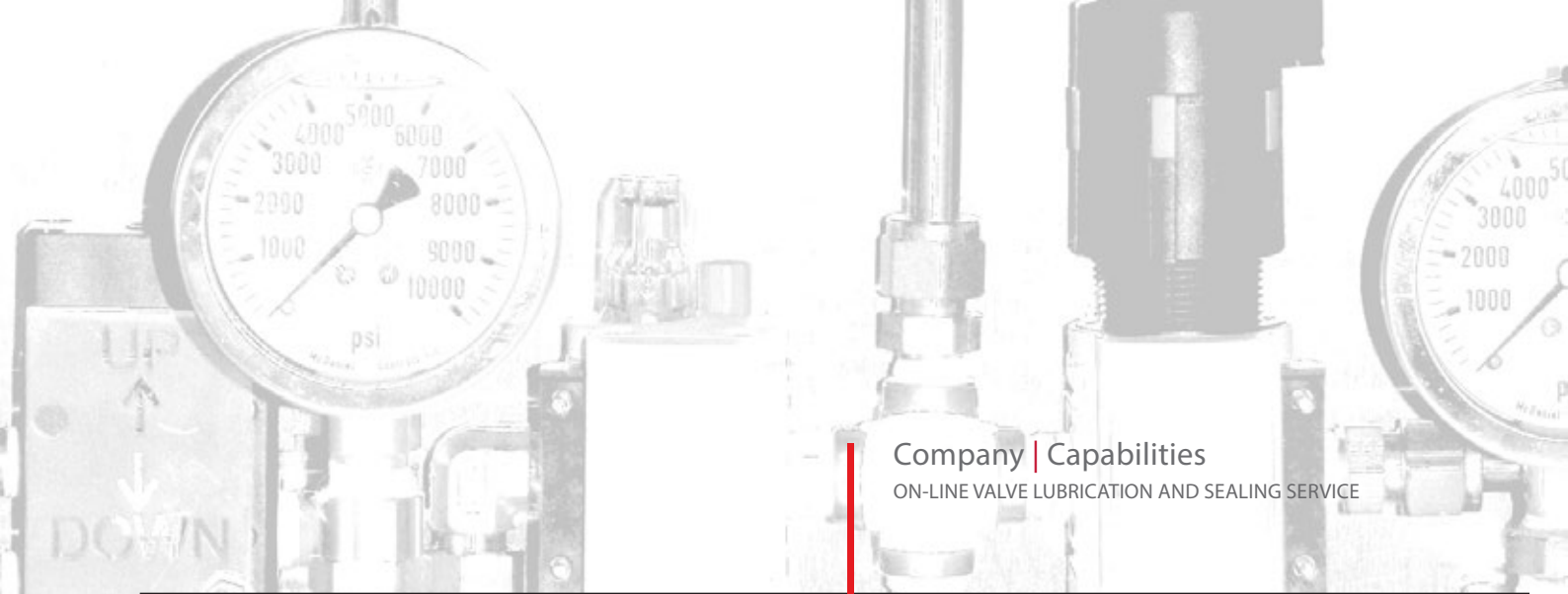

Company | Capabilities
ON-LINE VALVE LUBRICATION AND SEALING SERVICE



Lubrication / Sealing Pump Operating Procedures

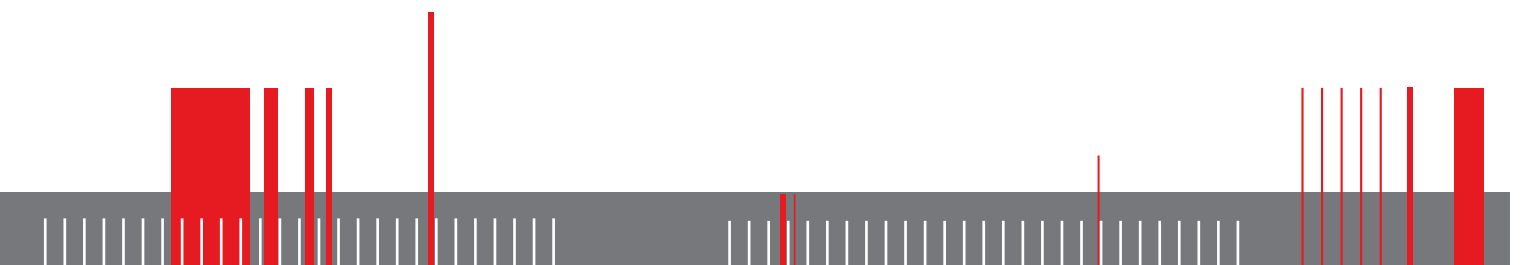



Lubrication / Sealing Pump Operating Procedures

STEP 1

- Position unit at desired location.
- Check that 3 way versa valve is in centre (neutral) position.
- Connect air supply.
- Check for leaks once the air has equalised.
- Set main regulator to 105 Psi.
- Check lubricator when operation pump to 6-10 drops/minute (minimum 6).

STEP 2

- Position the versa valve backward or down position to pressure equalize the air ram before raising the pump up.
- Position the versa valve forward to activate the air cylinder and raise the pump and the follower plate, so that a 40lb pail can be positioned.

STEP 3

- Open valve on follower plate.
- Position the versa valve backward to activate the air cylinder and lower the pump and the follower plate.
- Slowly lower pump and follower plate into the 40lb. Pail. (Note: insure that the pail is properly centred).
- Leave verse valve in down position. This provides a downward force to assist in pumping.
- Close valve on follower plate.

STEP 4

- Connect discharge hose.
- Slowly open main air supply ball valve to pump.
- Pump will start to cycle.
- Pump lubricant/sealant to clear hose and bleed air.
- Attach whip pump lubricant/sealant to clear and bleed air.
- Close whip ball valve and place proper fitting on swivel for job.
- Set counter, 14 strokes = 1 pound.

STEP 5

- To remove pail, position the versa valve forward to activate the air cylinder and raise the pump and follower plate to the fully raised position.
- Slowly open ball valve that directs air to the follower plate. This will blow the pail off.



Total Valve Care.

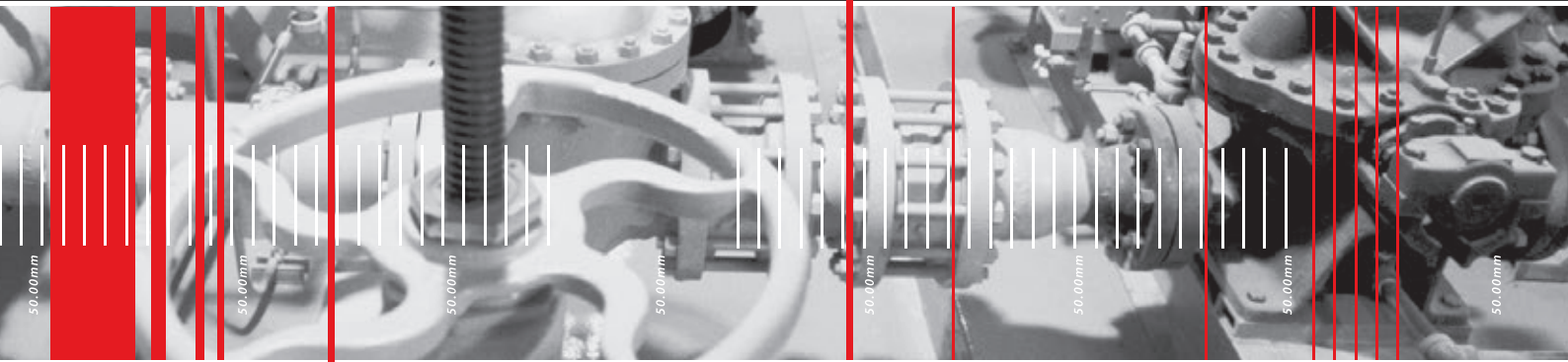

PRESSURELUBE
INTERNATIONAL

Pressure Lube International Pty Ltd

23 Jackson Street Bassendean

Western Australia 6054

Telephone +61 8 9379 1200

Facsimile +61 8 9279 9929

Email info@pressurelube.com.au

ABN 17 080 519 517

www.pressurelube.com.au